

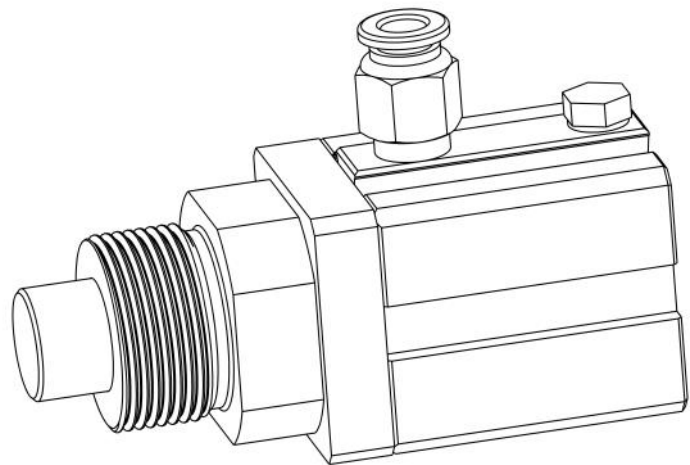

Air Clutch



PART NUMBERS:

5603: For H8P/H10P Winches



**SAVE THESE
INSTRUCTIONS**

CONTENTS

ITEM	QUANTITY	DESCRIPTION
1	1	Air Clutch

ANTI-SEIZE LUBRICANT MUST BE USED ON ALL STAINLESS STEEL FASTENERS TO PREVENT THREAD DAMAGE AND GALLING

INSTALLATION INSTRUCTIONS

1. Remove contents from box, verify if all parts listed are present and free from damage. **Failure to identify damage before installation could lead to a rejection of any claim.**
2. Carefully read and understand all instructions before attempting installation. **Ensure that all mounting hardware is torqued to specifications prior to use.**

3. Remove the manual clutch. See **Figure 1**.
4. Install the air clutch on top of the gearbox where the manual clutch was located. See **Figure 2**.

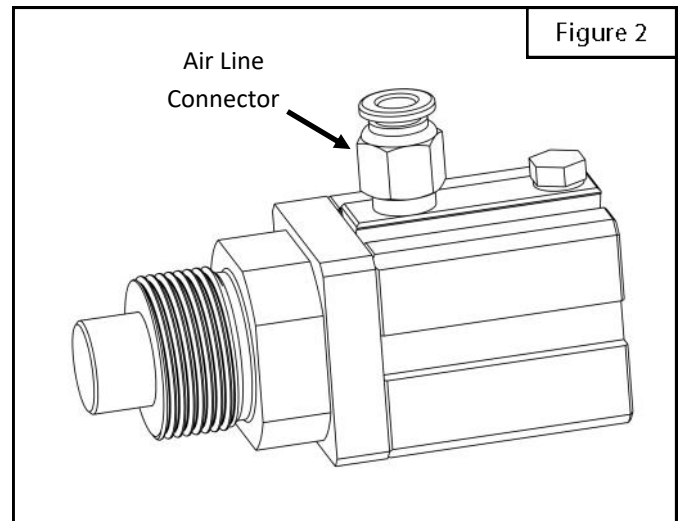
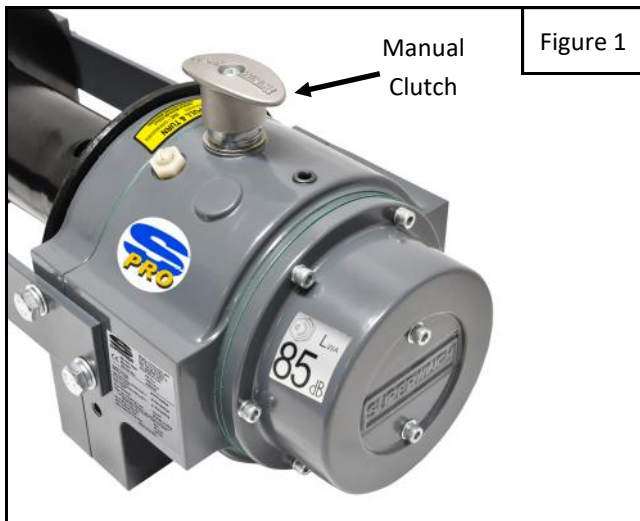

5. Connect an air line to the air line connector.
6. Apply air pressure to the air clutch to freespool the winch.

Failure to follow these instructions could lead to death, personal injury, and / or property damage.

FASTENERS:

All SUPERWINCH supplied fasteners must be utilized and installed in accordance with the installation instructions and apply torque to the specifications as defined. DOUBLE CHECK ALL FASTENERS BEFORE INITIAL USE, AND PERIODICALLY IN THE FUTURE TO ENSURE PROPER FUNCTION AND SAFETY.

EYE PROTECTION:

ALWAYS WEAR SAFETY GLASSES OR GOGGLES DURING THE INSTALLATION PROCESS TO AVOID PERSONAL INJURY.

FOR CALIFORNIA RESIDENTS ONLY-PROP 65 WARNING:

Some products may contain chemicals such as DEHP, which can cause cancer, birth defects or other reproductive harm. For more info go to www.p65warnings.ca.gov



For more information on this and other products,
or to be put in contact with a Superwinch sales
rep or distributor, call (800) 323- 2031
or email info@superwinch.com

SUPERWINCH
320 W. COVINA BLVD.
SAN DIMAS, CA 91773

© 2019 SUPERWINCH®, Superwinch®, and S Superwinch® (design) are registered trademarks of Superwinch Inc. in the United States and/or other countries.