

INSTALLATION INSTRUCTIONS

HDX Grille Guard



APPLICATION:
2020-2024 Chevrolet Silverado 2500/3500
PART NUMBER:
57-3990, 57-3995

ITEM	QUANTITY	DESCRIPTION	TOOLS NEEDED
1	1	GRILLE GUARD	RATCHET
2	1	LOWER DRIVER MOUNTING BRACKET	16MM SOCKET
3	1	LOWER PASSENGER MOUNTING BRACKET	17MM SOCKET
4	1	DRIVER INSIDE SUPPORT BRACKET	18MM SOCKET
5	1	PASSENGER INSIDE SUPPORT BRACKET	16MM WRENCH
6	1	DRIVER UPPER STRAP "A"	17MM WRENCH
7	1	PASSENGER UPPER STRAP "A"	18MM WRENCH
8	2	SHORT M12 HEX HEAD BOLT (YELLOW ZINC)	TORQUE WRENCH
9	4	LONG M12 HEX HAD BOLT (YELLOW ZINC)	CUTTING TOOL
10	6	M12 SPLIT LOCK WASHER (YELLOW ZINC)	
11	12	M12 FLAT WASHER (YELLOW ZINC)	
12	6	M12 HEX NUT (YELLOW ZINC)	
13	2	M10 BUTTON HEAD BOLT	
14	2	M10 BELLVILLE WASHER	
15	2	M10 SERRATED FLANGE NUT	
16	6	M12 BUTTON HEAD BOLT	
17	6	M12 SERRATED FLANGE NUT	
18	6	M12 BELLVILLE WASHER	
19	1	DRIVER CUTTING TEMPLATE "B"	
20	1	PASSENGER CUTTING TEMPLATE "B"	
21	1	DRIVER SUPPORT BRACKET "B"	
22	1	PASSENGER SUPPORT BRACKET "B"	
23	1	DRIVER CUTTING TEMPLATE "A"	
24	1	PASSENGER CUTTING TEMPLATE "A"	

ANTI-SEIZE LUBRICANT MUST BE USED ON ALL STAINLESS STEEL FASTENERS TO PREVENT THREAD DAMAGE AND GALLING.

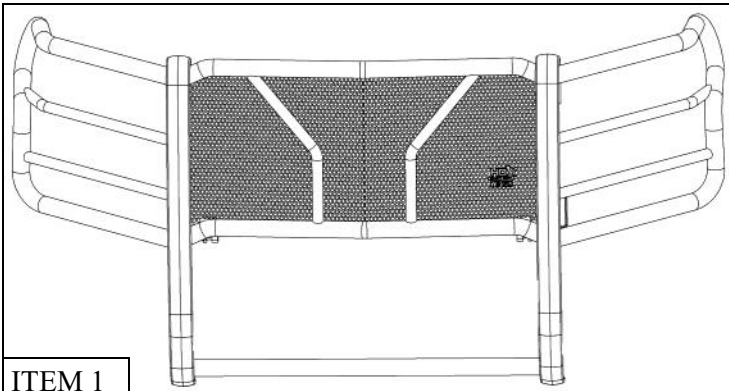

ITEM 1

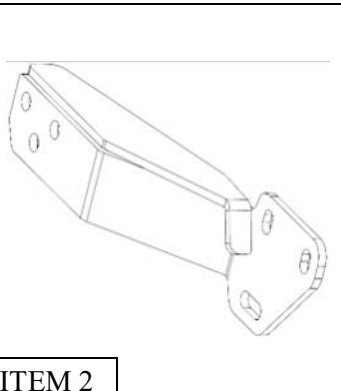

ITEM 2

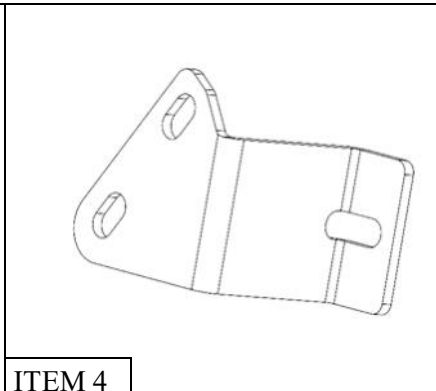

ITEM 4

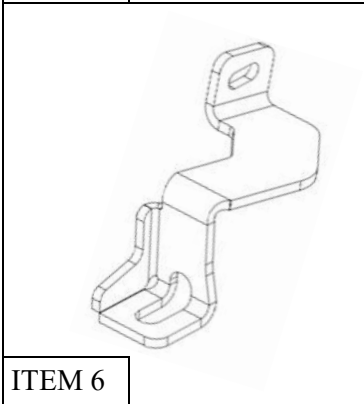

ITEM 6

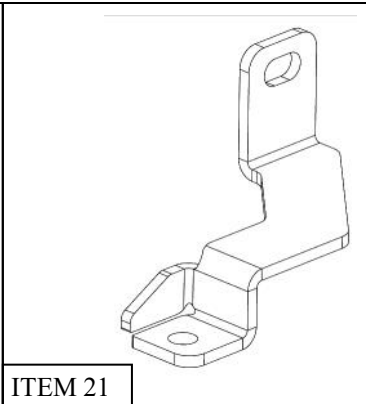

ITEM 21

PROCEDURE

- 1. Remove contents from box, verify if all parts listed are present and free from damage.
Carefully read and understand all instructions before attempting installation.
Failure to identify damage before installation could lead to a rejection of any claim.

2. Open the hood of the vehicle and remove the plastic cover at the front using a pry tool. See **Figure 1**.
3. Remove the four bolts holding the grille in place. See **Figure 2**.
4. Remove 2 bolts attaching wheel well cover to filler panel. See **Figure 3**.

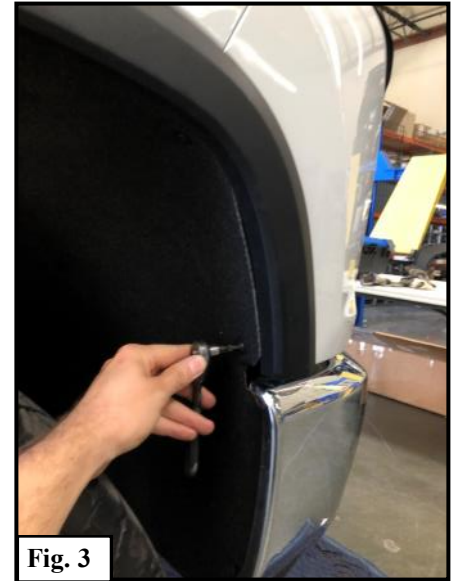
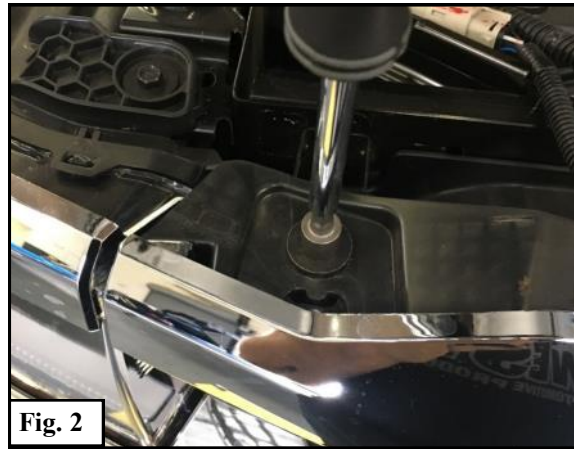

5. Pry off fenders to access the filler panel clips. See **Figure 4**.
6. Pry filler panel off removing any necessary bolts. See **Figure 5**.
7. Disconnect any electrical plugs and any bolts still attaching the grill to the vehicle. See **Figure 6**.
8. Pry remaining clips attaching the grill to the vehicle to remove the grille.

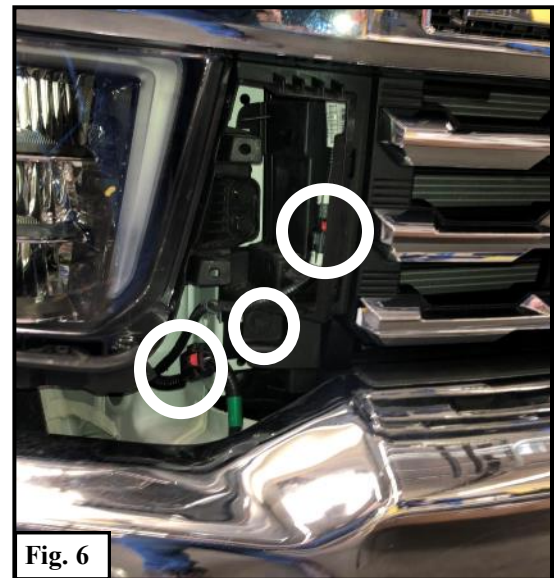
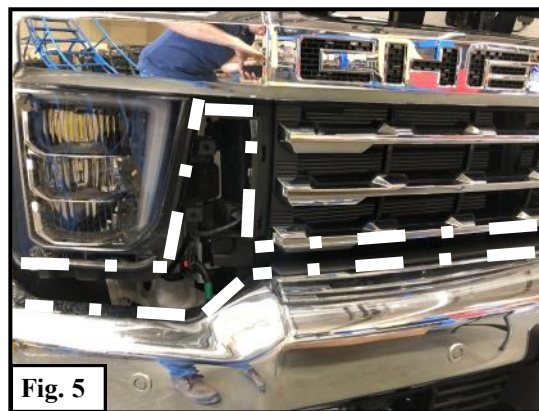

9. Remove 4 upper bumper bolts attaching the bumper to the frame and remove 2 bottom bolts attaching bumper arm to the frame. See **Figure 7 & 8.**

10. **Remove Bumper.**

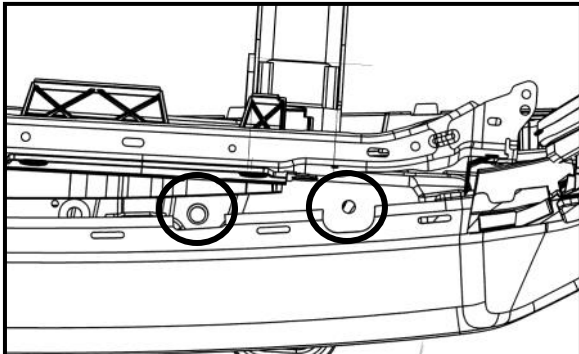

Fig. 7

Bolts will be exposed after removing the grille and lifting the plastic covering them

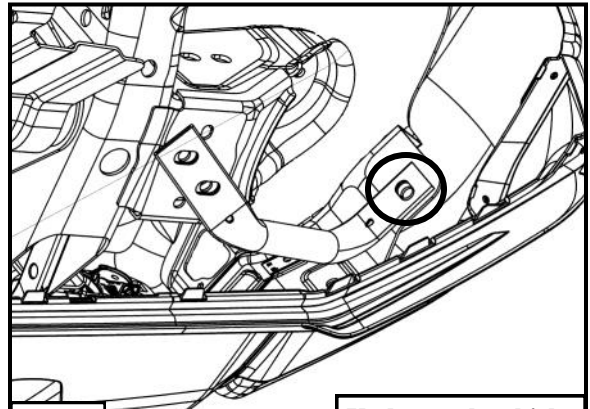

Fig. 8

Underneath vehicle

11. Locate the lower driver mounting and support brackets for the Grille Guard. Using the supplied M12 hardware, loosely install the mounting brackets on to the frame. The mounting bracket and support bracket (2-5) sandwich the frame. See **Figures 9 & 10.**

12. Repeat on the passenger side.

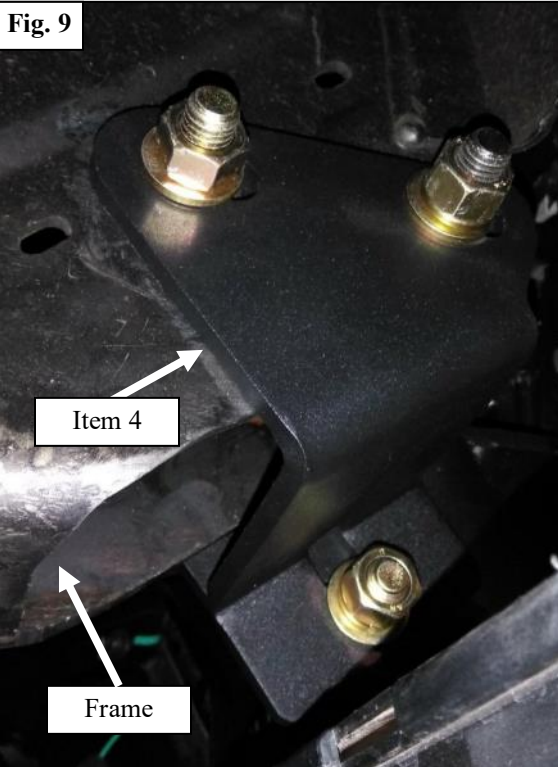

Fig. 9

Item 4

Frame

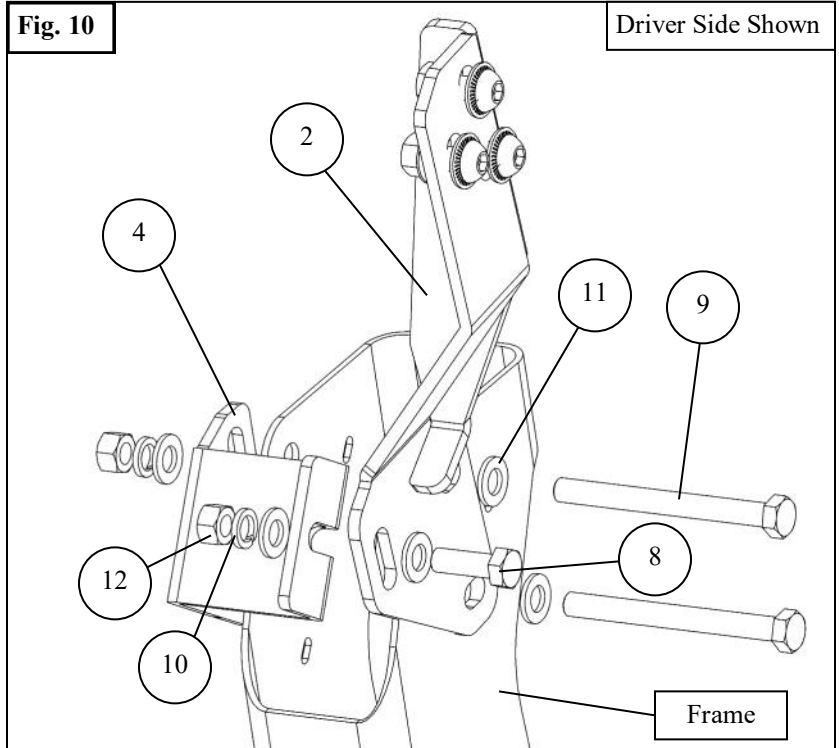

Fig. 10

Driver Side Shown

Frame

Bumper Valence Cutting Instructions 2020-2023

13. Locate the driver and passenger cutting templates (22-23). Starting on either side, along the template to the top corner of the valence. **See Figure 11.** Tape the template to the valence.
14. Using **Figures 11 & 12**, ensure that the measurements match your template. Follow the template instructions and cut accordingly. **Note: After cutting, you will still need to adjust your brackets and more cutting may be required!**

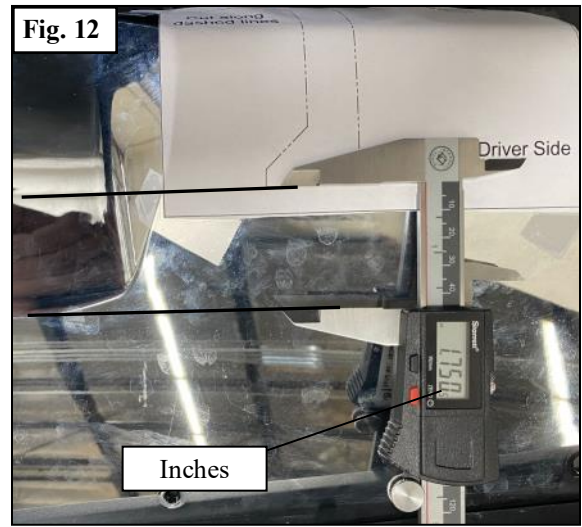
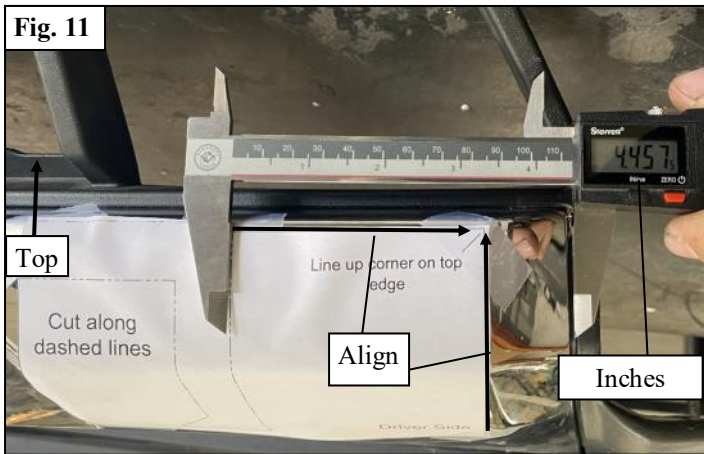

Bumper Valence Cutting Instructions 2024+

15. Locate the driver and passenger cutting templates "B" (19 & 20). Tape the driver side cutting template to the lower valence so that that the corner lines up with the edges shown below in **Figure 13**.
16. Repeat step 15 on the passenger side using the passenger cutting template "B".
17. Using **Figure 13**, ensure that the measurements match your template. Follow the template instructions and cut accordingly. **Note: After cutting, you will still need to adjust your brackets and more cutting may be required!**

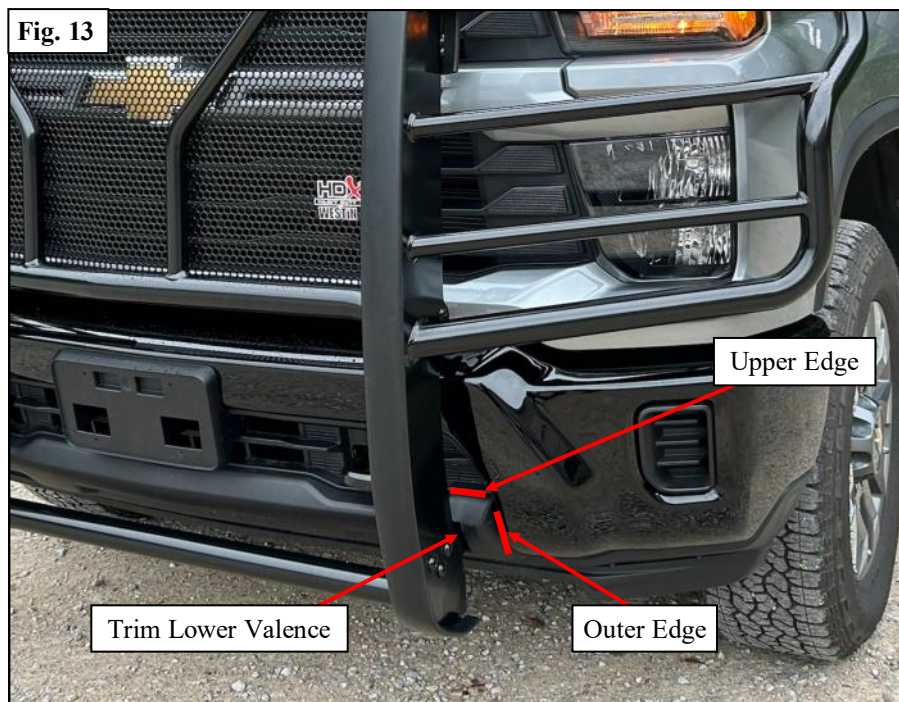

2020-2023 Upper Strap "A"

18. Locate the upper support straps "A" (6-7) for the grille guard. Loosely re-install the front bumper with the upper support straps. Reconnect all electrical connections. The upper factory bumper bolts will be used for the upper support straps. Measure the distance between the mounting surfaces of the upper straps and ensure it is about 42.25". Torque to 50-55 ft-lbs. See Figure 14 & 15.

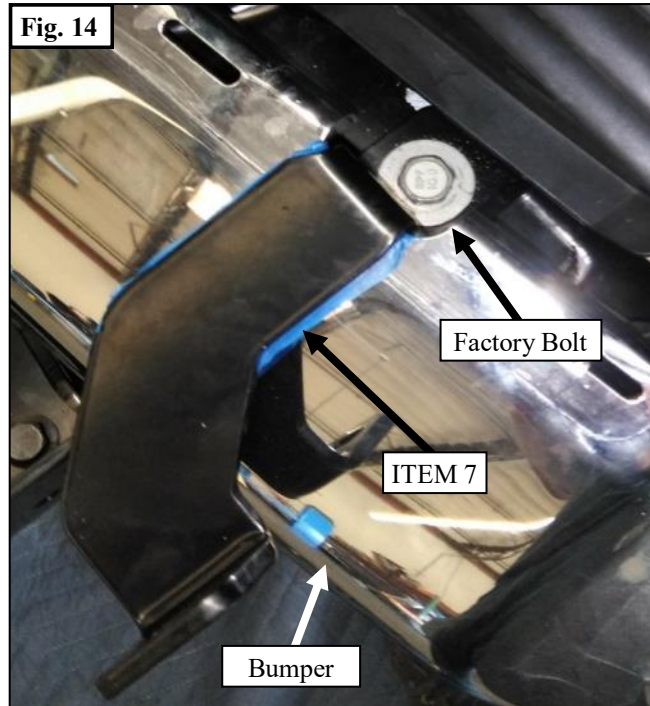

Fig. 15

42.25 inches



2024+ Upper Strap "B"

19. Remove the plastic trim shown in **Figure 16**.
20. Locate the upper support straps "B" (**items 36 and 37**). Loosely re-install the front bumper with the upper support straps "B". Reconnect all electrical connections. The upper factory bumper bolts will be used for the upper support straps.
21. Cut the plastic trim removed in Step 15 so that the bolt can be accessed. The results should look like **Figure 16**.
22. Reinstall the plastic cover. See **Figure 16**.
23. Measure the distance between the mounting surfaces of the upper straps "B" and ensure it is about 42.25". Torque to 50-55 ft-lbs.

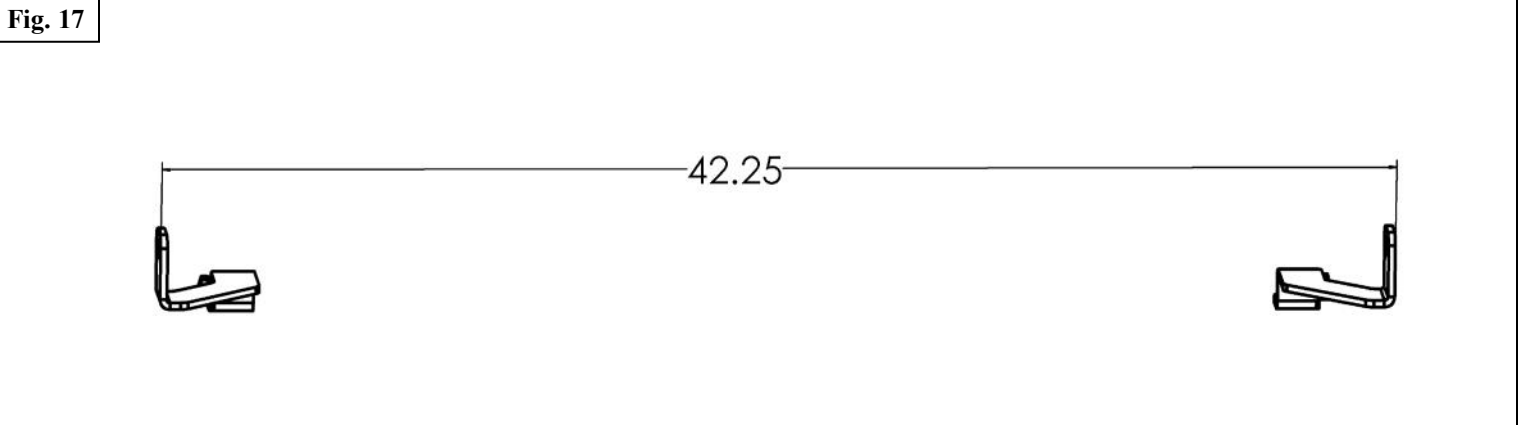

24. Reinstall the filler panel and grille.
25. With help, install the Grille Guard over the lower mount brackets and previously installed upper support brackets. Using the supplied M10 and M12 hardware. See **Figures 18&19.**
26. Align as necessary and torque all hardware as specified: M12 to 50-55 ft-lbs., M10 to 30-35 ft-lbs.

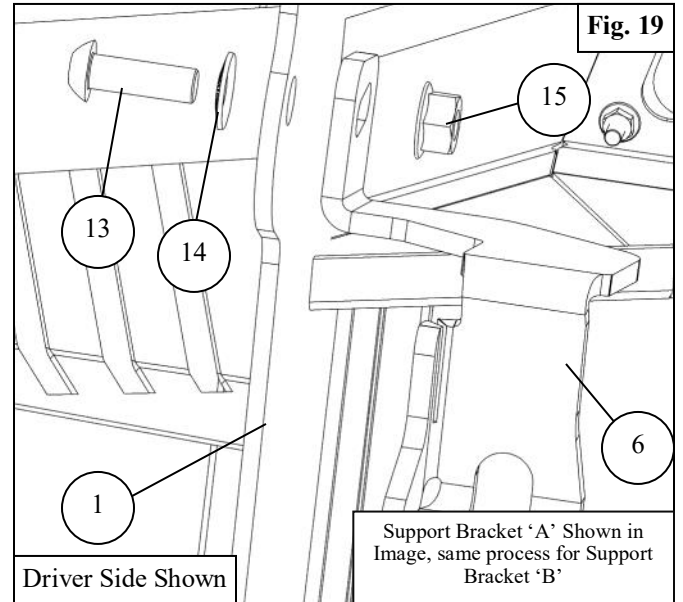
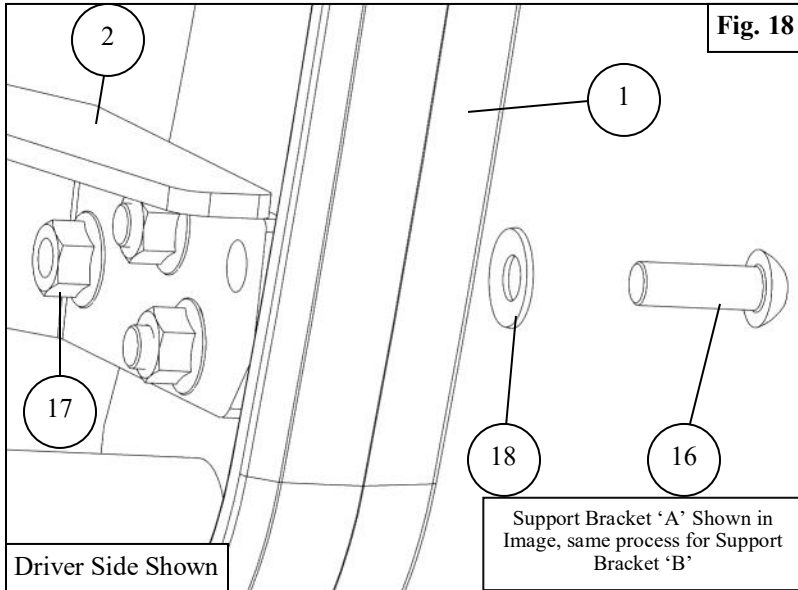

INSTALL COMPLETE



©2015 WESTIN AUTOMOTIVE PRODUCTS, INC. ALL RIGHTS RESERVED

CARE INSTRUCTIONS

- REGULAR WAXING IS RECOMMENDED. DO NOT USE ANY TYPE OF POLISH OR WAX THAT MAY CONTAIN ABRASIVES.
- STAINLESS STEEL PRODUCTS CAN BE CLEANED WITH MILD SOAP AND WATER. STAINLESS STEEL POLISH SHOULD BE USED TO POLISH SMALL SCRATCHES.
- GLOSS BLACK FINISHES SHOULD BE CLEANED WITH MILD SOAP AND WATER.

WESTIN Westin Automotive Products, Inc.
320 W. Covina Blvd
San Dimas, Ca. 91773

Thank You for choosing Westin products
For Additional installation assistance please call
Customer service (800) 793-7846
www.westinautomotive.com



WARNING



Failure to follow these instructions could lead to death, personal injury, and / or property damage.

Failure to follow these instructions could lead to death, personal injury, and / or property damage.

FASTENERS:

All Westin supplied fasteners must be utilized and installed in accordance with the installation instructions and apply torque to the specifications as defined. **DOUBLE CHECK ALL FASTENERS BEFORE INITIAL USE, AND PERIODICALLY IN THE FUTURE TO ENSURE PROPER FUNCTION AND SAFETY.**

DRILLING:

Most Westin products do not require drilling for installation. If drilling is defined as required, use caution when drilling a vehicle. **FAILURE TO REVIEW AN AREA TO BE DRILLED MAY RESULT IN PERSONAL INJURY AND/OR INJURY TO OTHERS AS WELL AS VEHICLE DAMAGE.**

EYE PROTECTION:

ALWAYS WEAR SAFETY GLASSES OR GOGGLES DURING THE INSTALLATION PROCESS TO AVOID PERSONAL INJURY.

MAXIMUM TOWING/CARRYING CAPACITY: (if applicable)

The Westin Receiver Hitches will have a visible tow rating label affixed directly on the product. User should never exceed the vehicle manufacturers maximum tow and weight rating regardless of the capacity of the hitch. **FAILURE TO FOLLOW THESE GUIDELINES WILL VOID THE WESTIN WARRANTY AND MAY RESULT IN PERSONAL INJURY AND/OR INJURY TO OTHERS AS WELL AS VEHICLE DAMAGE.**

FOR CALIFORNIA RESIDENTS ONLY-PROP 65 WARNING:

Some products may contain chemicals such as DEHP, which can cause cancer, birth defects or other reproductive harm. For more info go to www.p65warnings.ca.gov



Westin Automotive Products, Inc.
320 W. Covina Blvd
San Dimas, Ca. 91773

Thank You for choosing Westin products
For Additional installation assistance please call
Customer service (800) 793-7846
www.westinautomotive.com