

INSTALLATION INSTRUCTIONS

HDX MODULAR GRILLE GUARD



APPLICATION:
TUNDRA CREWMAX 22+

PART NUMBER:
57-24095

CONTENT			
ITEM	QUANTITY	DESCRIPTION	TOOLS NEEDED
1	1	GRILLE GUARD BASE ASSEMBLY	
2	1	DRIVER SIDE WING	
3	1	PASSENGER SIDE WING	
4	1	DRIVER SIDE MAIN BRACKET	
5	1	PASSENGER SIDE MAIN BRACKET	
6	1	DRIVER SIDE SUPPORT BRACKET	
7	1	PASSENGER SIDE SUPPORT BRACKET	
8	1	DRIVER SIDE OE BUMPER SUPPORT STRAP	
9	1	PASSENGER SIDE OE BUMPER SUPPORT STRAP	
10	2	M12 OD FLAT WASHERS (BLACK ZINC)	
11	4	M12 SOCKET BUTTON HEAD BOLTS (BLACK ZINC)	
12	4	M12 SERRATED BELLVILLE WASHERS (BLACK ZINC)	
13	2	M12 SERRATED FLANGE HEX NUTS (BLACK ZINC)	
14	2	M12 HEX HEAD BOLTS (BLACK ZINC)	
15	10	M8 HEX SOCKET BUTTON HEAD BOLTS (BLACK ZINC)	
16	10	M8 BELLVILLE WASHERS (BLACK ZINC)	
17	10	M8 SERRATED FLANGE NUT(BLACK ZINC)	
18	4	M8 SERRATED FLANGE NUT (YELLOW ZINC)	
19	6	M8 SOCKET BUTTON HEAD BOLTS (YELLOW ZINC)	
20	2	NYLOCK HEX NUT (YELLOW ZINC)	
21	4	M8 FLAT WASHER 16mm OD (YELLOW ZINC)	
22	4	M8 FLAT WASHER 25mm OD (YELLOW ZINC)	

ANTI-SEIZE LUBRICANT MUST BE USED ON ALL STAINLESS STEEL FASTENERS TO PREVENT THREAD DAMAGE AND GALLING

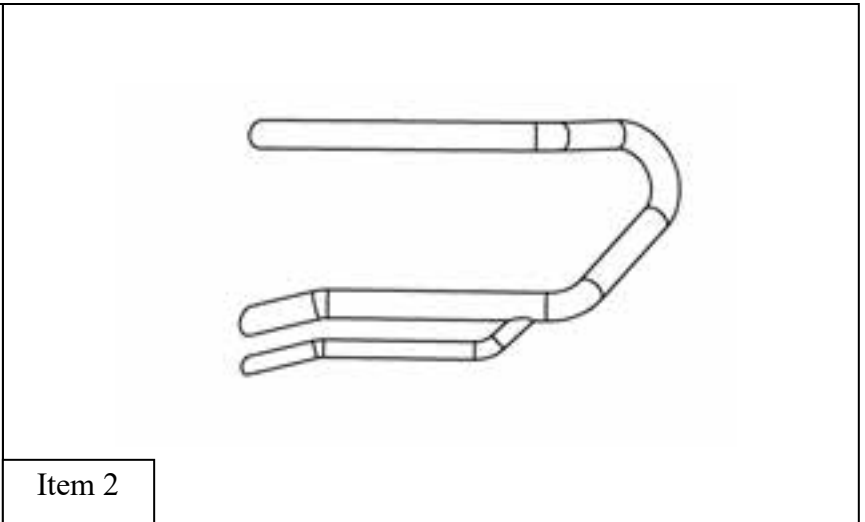
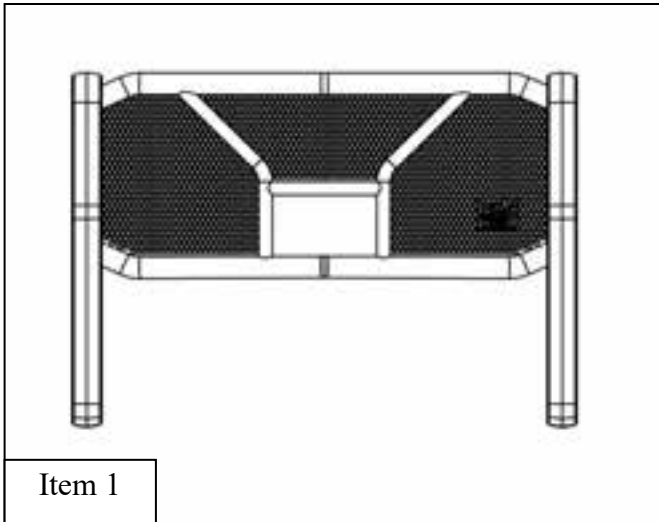

Item 1

Item 2

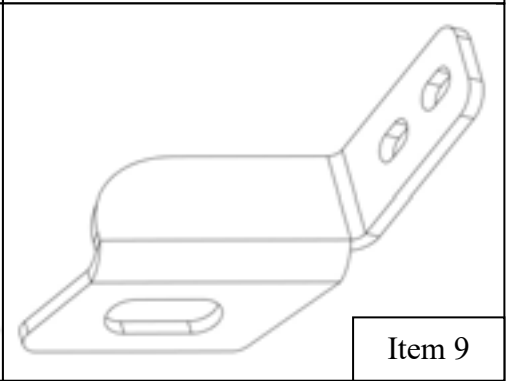
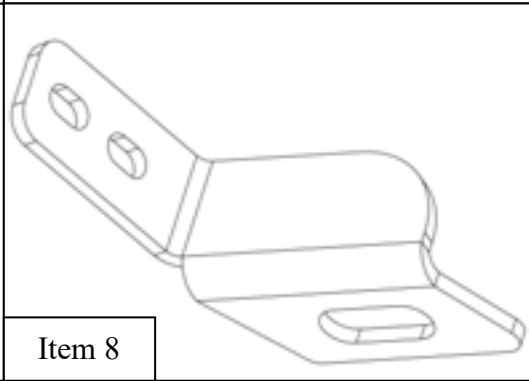
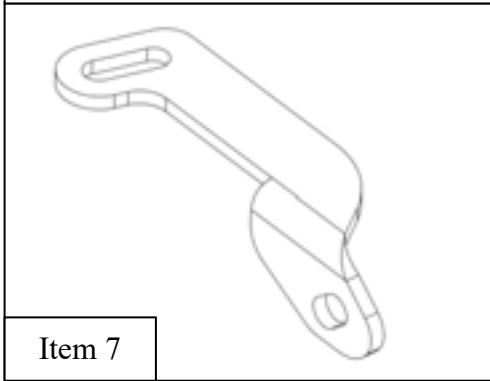
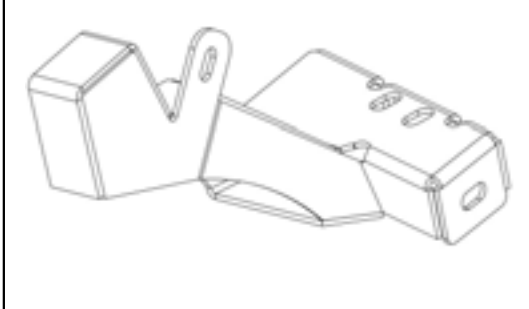

Item 4

Item 5

Item 6

Item 7

Item 8

Item 9

PROCEDURE

1. Remove contents from box, verify if all parts listed are present and free from damage.
Carefully read and understand all instructions before attempting installation.
Failure to identify damage before installation could lead to a rejection of any claim.

OE Bumper Removal

2. Remove the bolts that are located on the top of the Grille, attached to the radiator support . See **Figure 1** for reference.
3. Remove the plastic clips and the electrical connectors that are located on the driver and passenger side of the front bumper. See **Figure 2 & 3** for reference.
4. Remove the bolts and plastic clips that are located by the fenders and on the bottom of the front bumper.
5. Remove the fender flares and using a flat head screwdriver pop out the side of the front bumper. Repeat on the driver side. See **Figure 4 & 5** for reference.
6. Continue by pulling the front bumper off the truck. Some force will be needed.

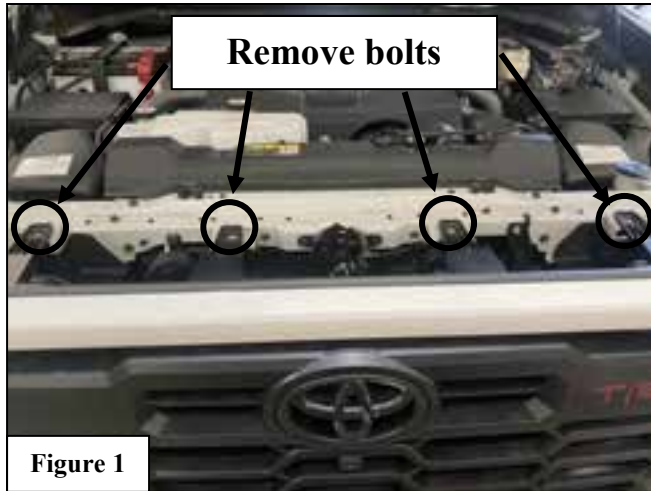

OE Bumper Disassembly and Trimming

- 6. Cautiously disconnect all four front parking sensors attached on the front bumper. See **Figure 6, 7, & 8** for reference. **NOTE:** Make sure to cautiously disconnect the sensor and remember the location and orientation to prevent any malfunctions.
- 7. To begin to disassemble the front bumper, start by removing the left and right side of the bumper which is held on by 6 screws. See **Figure 6 & 7** for reference. **NOTE:** The wire harness will be removed as the front bumper is disassembled along the way.
- 8. Remove the bolts and wire connector on the top right that hold the active shutters. See **Figure 8** for reference.

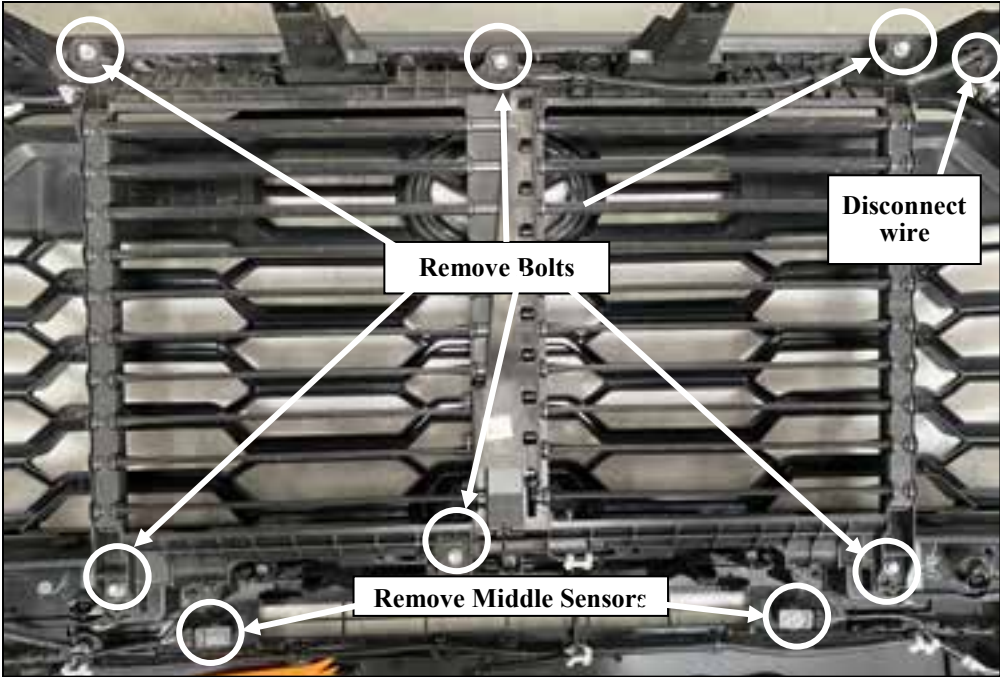
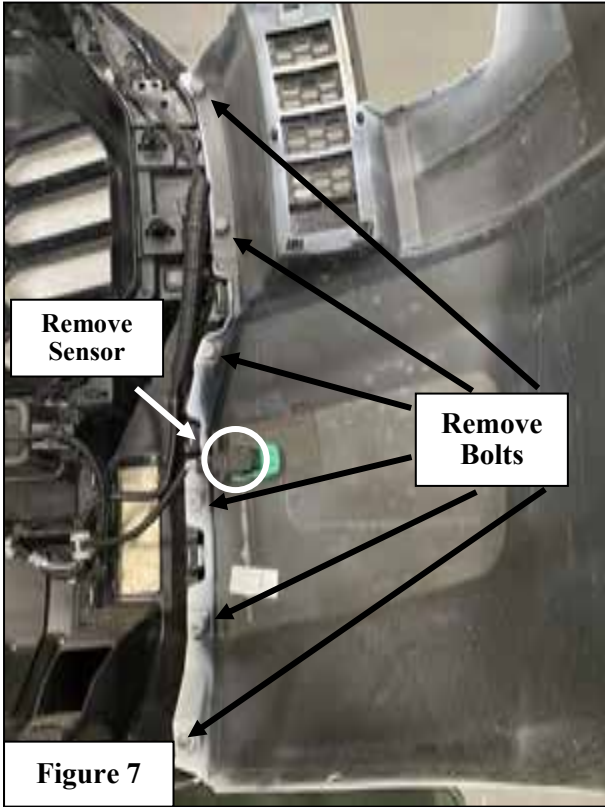
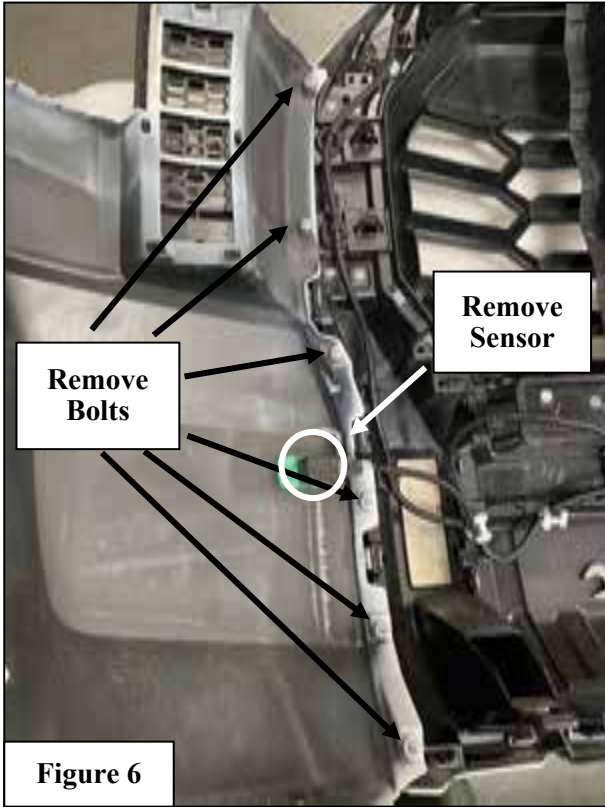

9. Proceed by removing the screws located all around the border of the front bumper. See **Figure 9, 10, & 11** for reference.
10. Begin removing the plastic clips all along the edge of the front bumper. This will remove the top trim piece of the assembly. See **Figure 9, 10, & 11** for reference.
11. To remove the front gloss piece of the grille, remove the plastic clips. See **Figure 9, 10, & 11** for reference.
12. Begin removing the plastic clips that holds the wire harness to disassemble the front bumper assembly



13. Carefully disconnect and remove the bolts that hold the cruise control sensor. See **Figure 12** for reference. **NOTE:** *When handling the sensor make sure to place the sensor in a safe space to prevent any malfunction.*
14. Disconnect the two wires that are connected to the fog lights. Continue to take out any plastic clips that are holding the wire harness together. See **Figure 13** for reference.
15. Continue to remove the last two pieces of the assembly by removing the plastic clips. See **Figure 13** for reference.

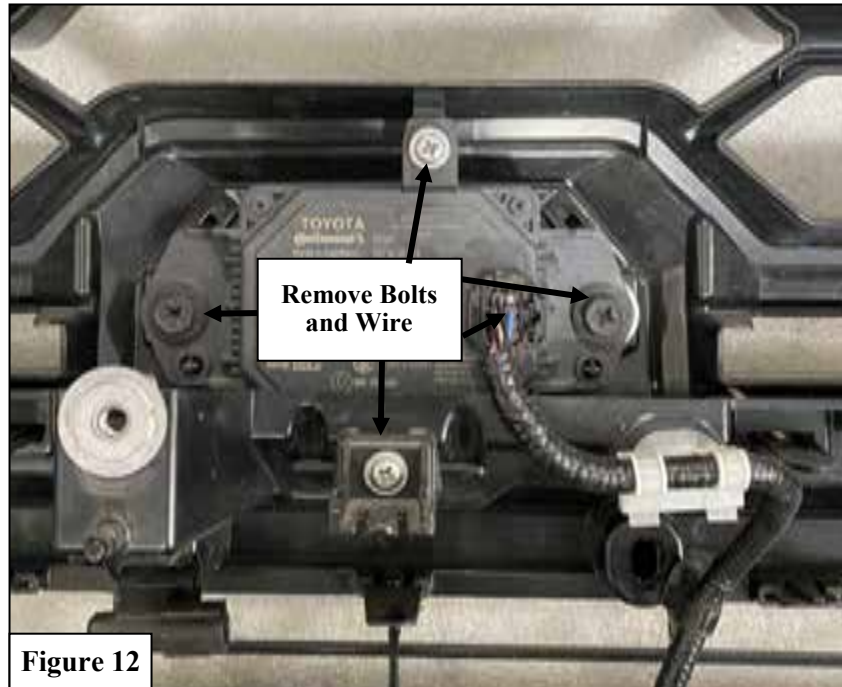

Figure 12

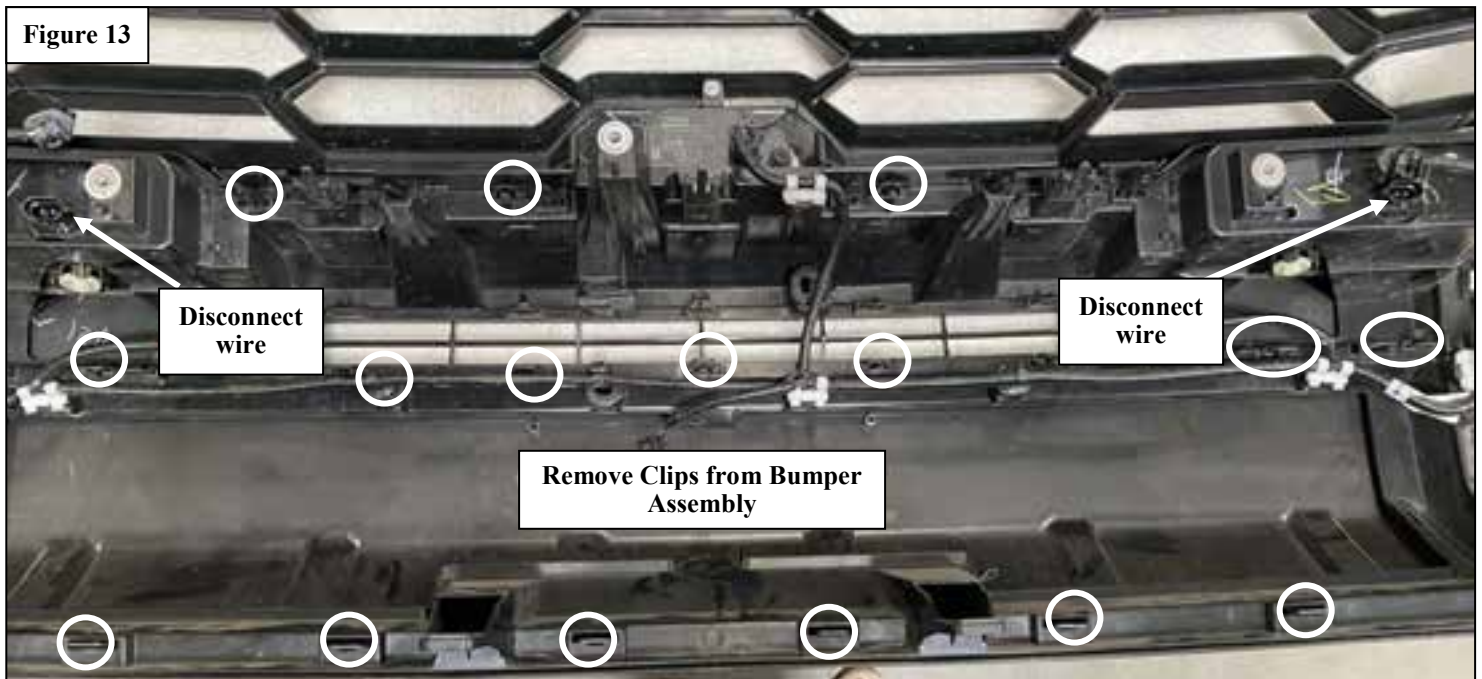
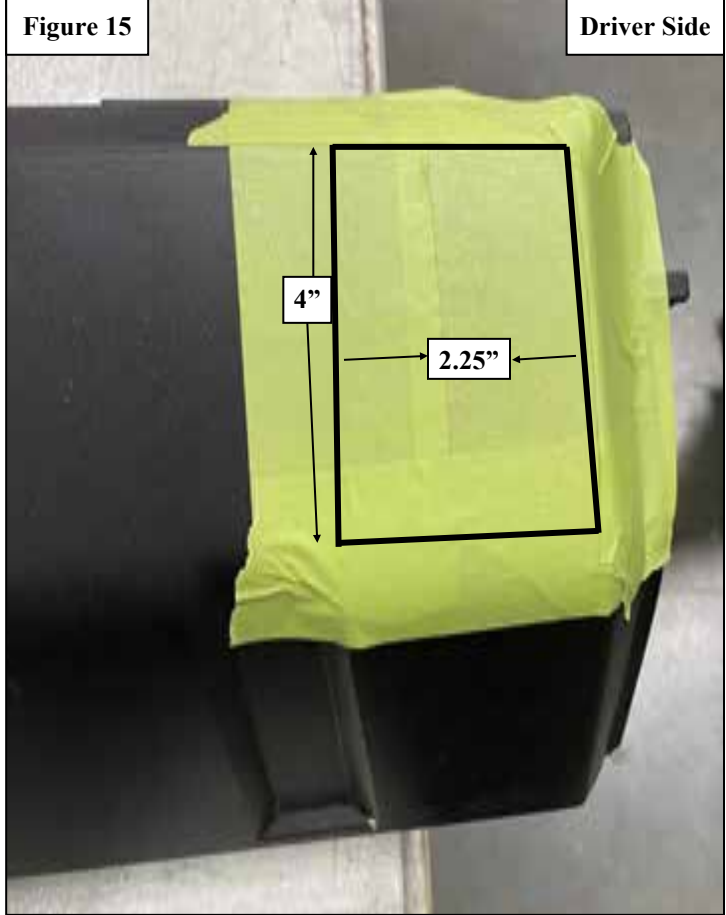
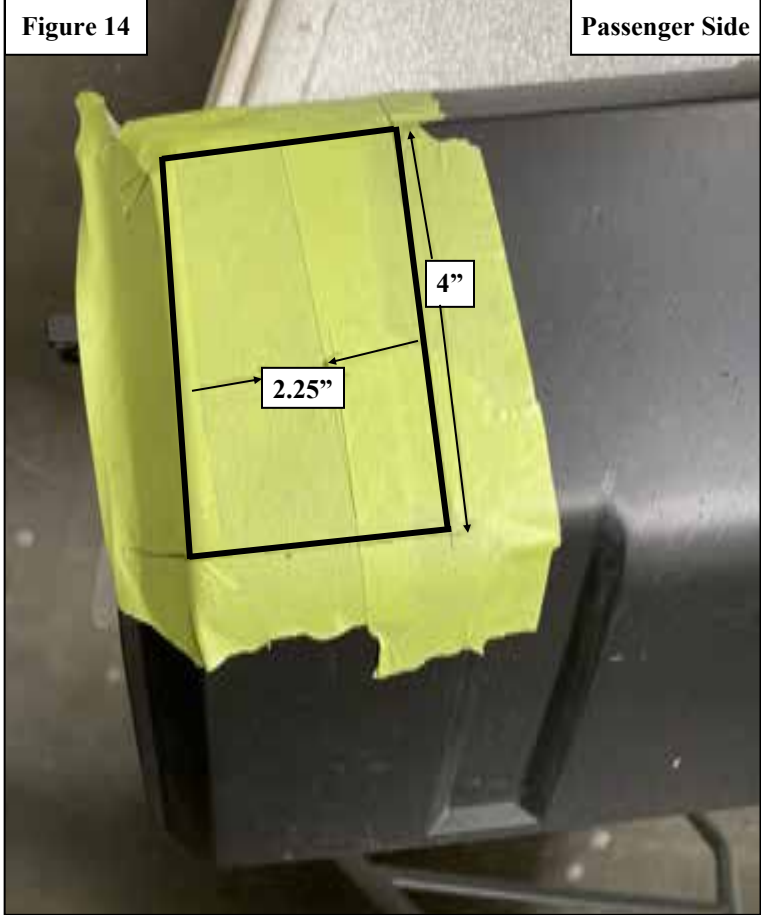
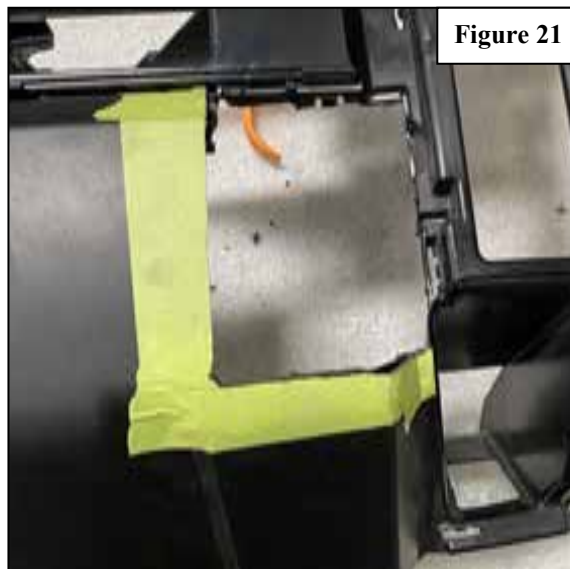
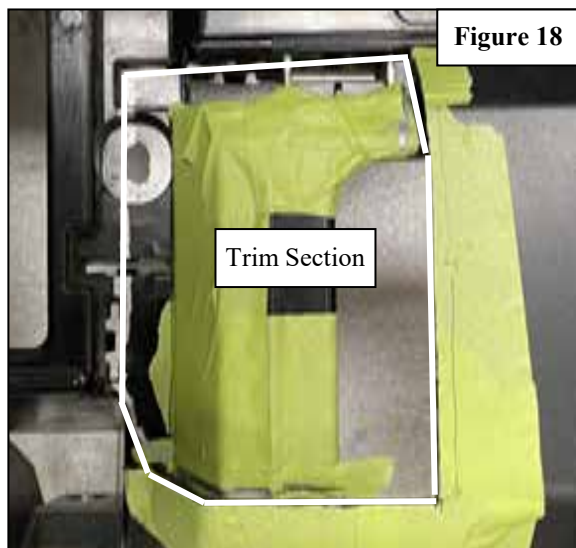

Figure 13

16. Once the front bumper has been fully disassembled, locate the bottom piece to begin prepping to trim.
17. Tape the bottom piece of the bumper. See **Figure 14 & 15** for reference.
18. Trim the bottom piece of the bumper. It should measure 2.25" wide and 4" tall. See **Figure 14 & 15** for reference. See **Figure 16 & 17** to see how the bottom piece of the bumper should look.



19. Prep the location that is located behind the trimmed piece that was done in **Step 18**. See **Figures 18 & 19** for reference.
20. The finished product should look something similar to **Figures 20 & 21** for reference.
21. Assemble the bumper together again. **NOTE:** *Make sure to attach the sensors to the right location on to the assembled bumper*



HDX Grille Guard Install

22. Remove the bottom bolts that are attached to the crash bar. **NOTE:** Save OEM bolts since they will be reused.
23. On the top of the crash bar remove the outer bolts and loosen the inner bolts. See **Figure 26** to help find the inner and outer bolts.
24. Using the OEM hardware attach the Driver Side Support Bracket (**Item 6**) to the crash bar. See **Figure 22** for reference.
25. Using the OEM hardware that was removed loosely attach the Driver Side Main Bracket (**Item 4**). See **Figure 23** for reference.

Figure 22



Figure 23

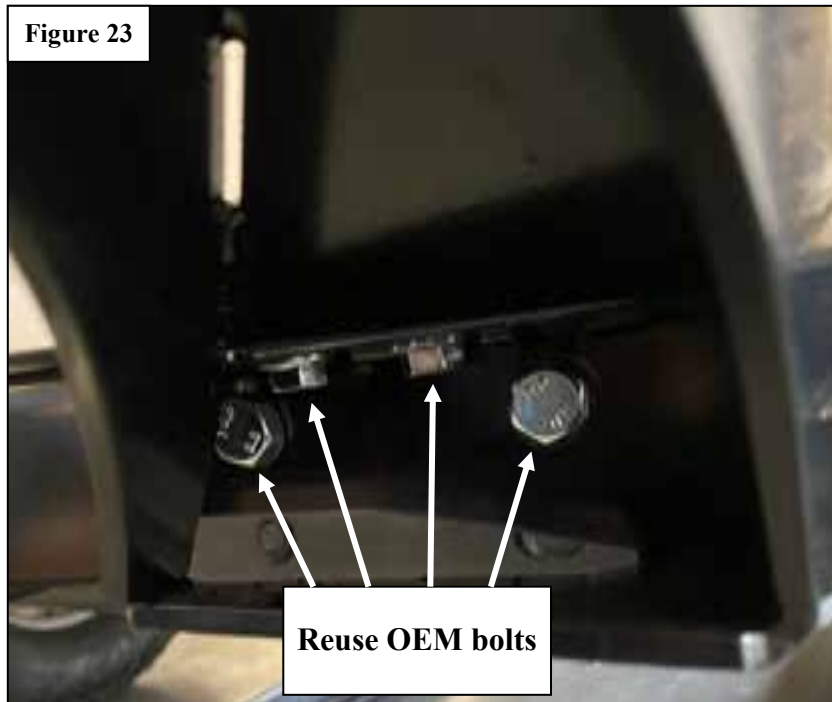

26. Using the provided M12 hardware loosely attach Driver Side Support Bracket and the Driver Side Main Bracket. See **Figure 24** for reference.
27. Using the provided M8 hardware loosely attach the Driver Side OE Bumper Support Strap (**Item 6**) to the Driver Side Main Bracket. See **Figure 25** for reference.
28. Repeat **Steps 24-27** on the Passenger Side so that the crash bar can look like **Figure 26**. Then adjust and center brackets to 43.5 inches wide, and tighten all M12 hardware to 75Ft-lbs, starting with the hardware on the bottom of the crash bar.
29. Then, loosen all M12 hardware with the exception of the two M12 bolts on top of the crash bar, circled in **Figure 26**. Loosen the hardware so the main brackets hang as shown on **Figure 22**.

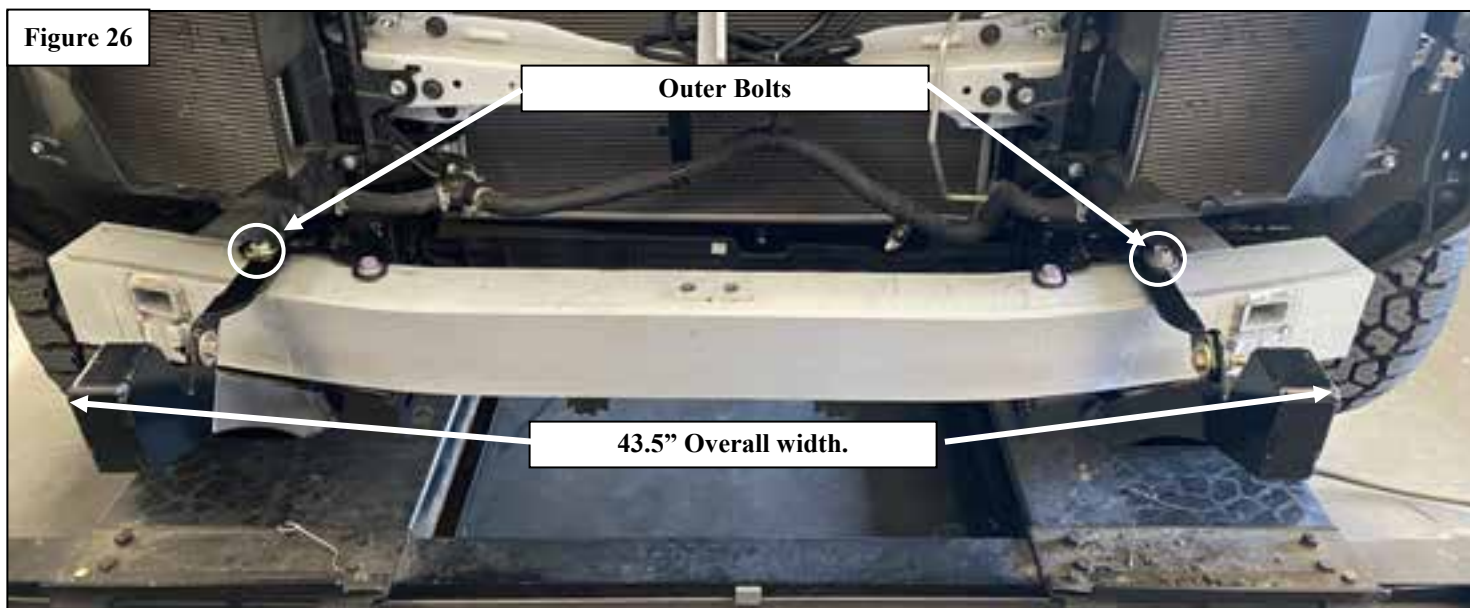
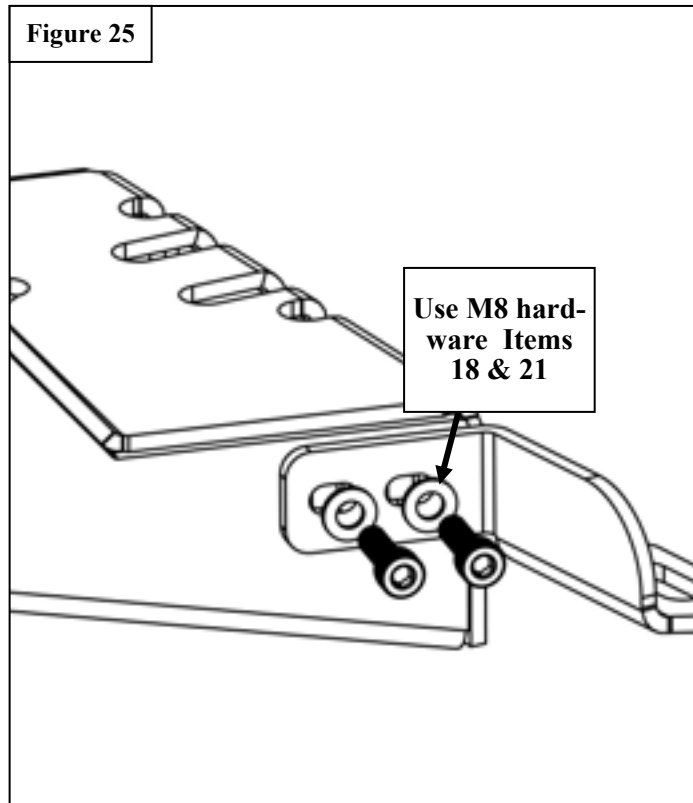

30. Fully re-assemble the trimmed bumper-grille assembly on work bench and re-install on the vehicle. Some force may be required, but leaving the main brackets hanging should help get the bumper in place.
31. Once the bumper is installed, carefully install M12 hardware shown on **Figure 24**. Then, tighten hardware on bottom of crash bar first, then continue with the hardware for the upper support brackets. See **Figure 27**.
31. Attach the OE Bumper Support Straps to the Front Bumper. See **Figure 28**.
32. Using the provided M12 hardware attach the Grille Guard (**Item 1**) to the Driver and Passenger Main Bracket. See **Figure 29** for reference. Tighten all M8 hardware to 15-18 ft-lbs. and M12 hardware to 50-55 ft-lbs.



Figure 27



Figure 28

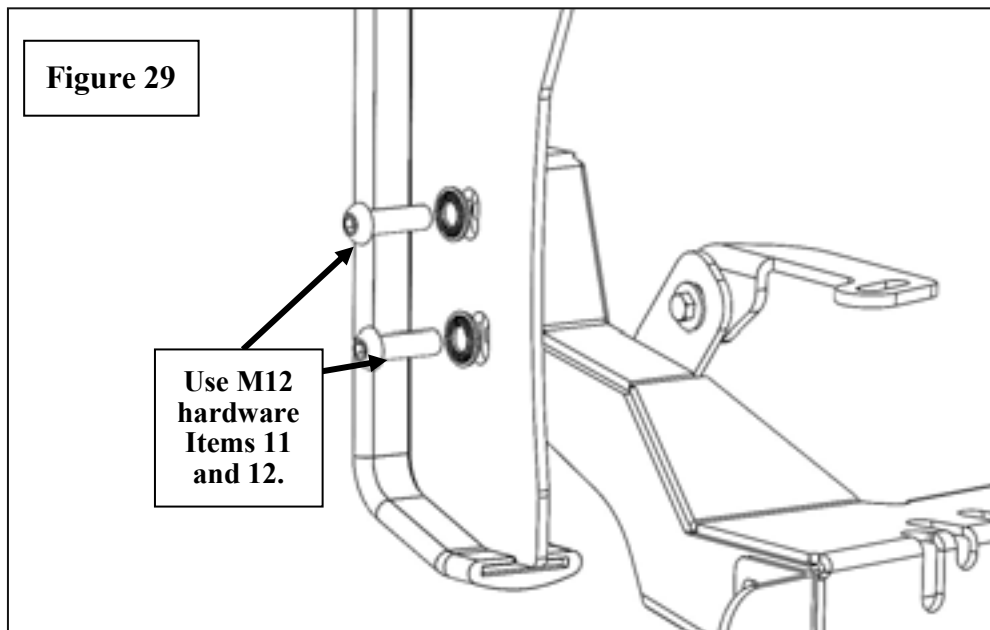

Figure 29

Use M12 hardware Items 11 and 12.



Use M8 hardware Items 19,20 and 22.

33. Install the driver and passenger wings (**items 2&3**), using the (10) M8 Hex Socket Button head bolt hardware (**items 15-17**).
See **Figure 30**.
34. Tighten all hardware.

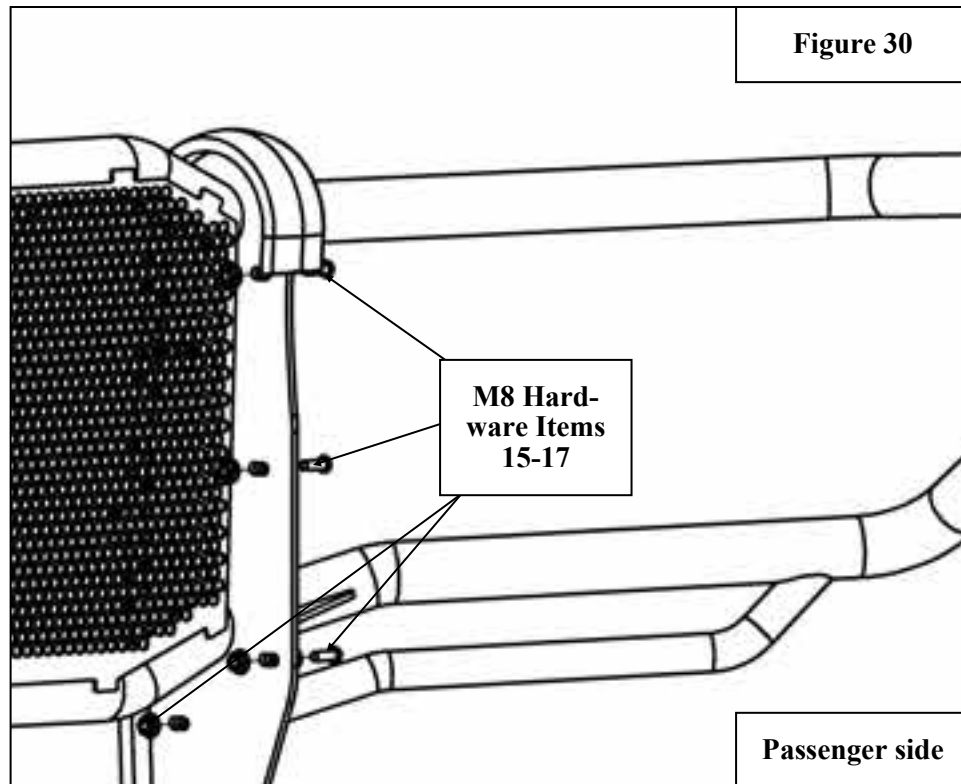

INSTALLATION COMPLETE



Pre-Production model shown. Actual product will look like image on page 1.
Shown with optional Superwinch Hidden Winch Tray P# 204095.

CARE INSTRUCTIONS

- REGULAR WAXING IS RECOMMENDED. DO NOT USE ANY TYPE OF POLISH OR WAX THAT MAY CONTAIN ABRASIVES.
- STAINLESS STEEL PRODUCTS CAN BE CLEANED WITH MILD SOAP AND WATER. STAINLESS STEEL POLISH SHOULD BE USED TO POLISH SMALL SCRATCHES.
- GLOSS BLACK FINISHES SHOULD BE CLEANED WITH MILD SOAP AND WATER.



WARNING



Failure to follow these instructions could lead to death, personal injury, and / or property damage.

Failure to follow these instructions could lead to death, personal injury, and / or property damage.

FASTENERS:

All Westin supplied fasteners must be utilized and installed in accordance with the installation instructions and apply torque to the specifications as defined. **DOUBLE CHECK ALL FASTENERS BEFORE INITIAL USE, AND PERIODICALLY IN THE FUTURE TO ENSURE PROPER FUNCTION AND SAFETY.**

DRILLING:

Most Westin products do not require drilling for installation. If drilling is defined as required, use caution when drilling a vehicle. **FAILURE TO REVIEW AN AREA TO BE DRILLED MAY RESULT IN PERSONAL INJURY AND/OR INJURY TO OTHERS AS WELL AS VEHICLE DAMAGE.**

EYE PROTECTION:

ALWAYS WEAR SAFETY GLASSES OR GOGGLES DURING THE INSTALLATION PROCESS TO AVOID PERSONAL INJURY.

MAXIMUM TOWING/CARRYING CAPACITY: (if applicable)

The Westin Receiver Hitches will have a visible tow rating label affixed directly on the product. User should never exceed the vehicle manufacturers maximum tow and weight rating regardless of the capacity of the hitch. **FAILURE TO FOLLOW THESE GUIDELINES WILL VOID THE WESTIN WARRANTY AND MAY RESULT IN PERSONAL INJURY AND/OR INJURY TO OTHERS AS WELL AS VEHICLE DAMAGE.**

FOR CALIFORNIA RESIDENTS ONLY-PROP 65 WARNING:

Some products may contain chemicals such as DEHP, which can cause cancer, birth defects or other reproductive harm. For more info go to www.p65warnings.ca.gov



Westin Automotive Products, Inc.
320 W. Covina Blvd
San Dimas, Ca. 91773