

# INSTALLATION INSTRUCTIONS

## HDX Winch Mount Grille Guard



**APPLICATION:**  
2020-2024 Chevrolet Silverado 2500/3500  
**PART NUMBER:**  
Complete Kit: 57-93995  
Winch Tray Kit: 46-23995

**NOTE: Winch Tray Kit packaged separately.**

ITEM	QUANTITY	DESCRIPTION	TOOLS NEEDED
1	1	GRILLE GUARD	RATCHET
2	1	MAX WINCH TRAY	ALLEN KEY
3	1	LOWER DRIVER MOUNTING BRACKET	16MM SOCKET
4	1	LOWER PASSENGER MOUNTING BRACKET	17MM SOCKET
5	1	DRIVER INSIDE SUPPORT BRACKET	18MM SOCKET
6	1	PASSENGER INSIDE SUPPORT BRACKET	16MM WRENCH
7	1	DRIVER UPPER STRAP "A"	17MM WRENCH
8	1	PASSENGER UPPER STRAP "A"	18MM WRENCH
9	1	DRIVER UPPER STRAP "B"	TORQUE WRENCH
10	1	PASSENGER UPPER STRAP "B"	CUTTING TOOL
11	2	SPACER BLOCK	
<b>MAX WINCH TRAY HARDWARE</b>			
12	14	M12 FLAT WASHER (BLACK ZINC)	
13	8	M12 SPLIT LOCK WASHER (BLACK ZINC)	
14	6	M12 HEX NUT (BLACK ZINC)	
15	6	LONG M12 HEX HEAD BOLT CLASS 10.9 (BLACK ZINC)	
16	2	SHORT M12 HEX HEAD BOLT (BLACK ZINC)	
17	4	M12 SERRATED FLANGE HEX NUT (BLACK ZINC)	
18	4	M12 SERRATED FLANGE HEX HEAD BOLT (BLACK ZINC)	
<b>GRILLE GUARD HARDWARE</b>			
19	6	M12 HEX HEAD FLANGE BOLT (BLACK ZINC)	
20	12	M12 SERRATED FLANGE HEX NUT (BLACK ZINC)	
21	2	M10 HEX SOCKET BUTTON HEAD BOLT (BLACK ZINC)	
22	2	M10 BELLVILLE WASHER (BLACK ZINC)	
23	2	M10 SERRATED FLANGE HEX NUT (BLACK ZINC)	
24	6	M12 BELLVILLE WASHER (BLACK ZINC)	
25	6	M12 HEX SOCKET BUTTON HEAD BOLT (BLACK ZINC)	
<b>ANTI-SEIZE LUBRICANT MUST BE USED ON ALL STAINLESS STEEL FASTENERS TO PREVENT THREAD DAMAGE AND GALLING.</b>			

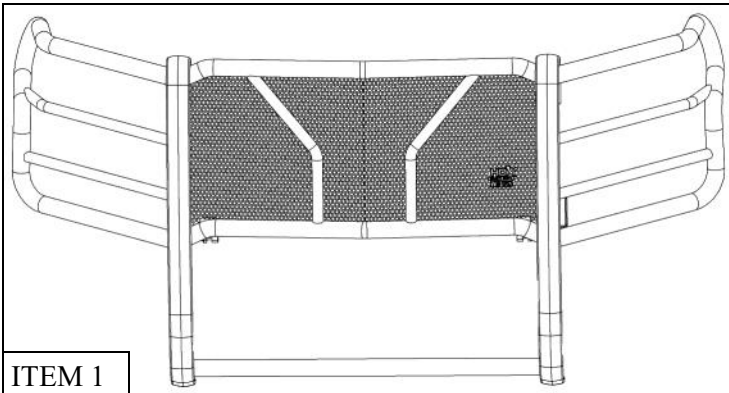

ITEM 1

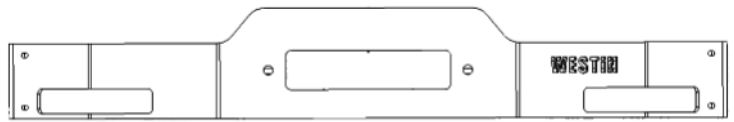

ITEM 2



ITEM 3

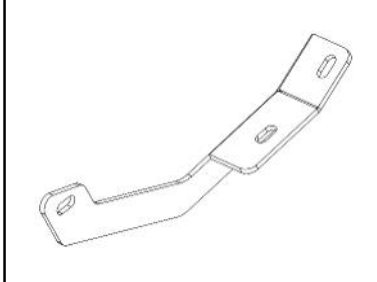

ITEM 5

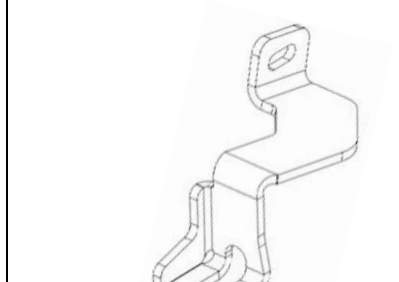

ITEM 7

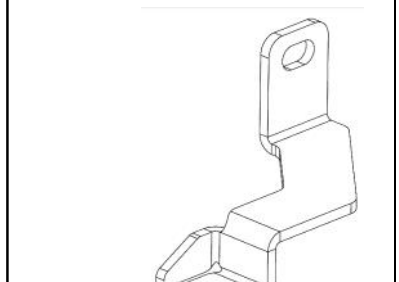

ITEM 9

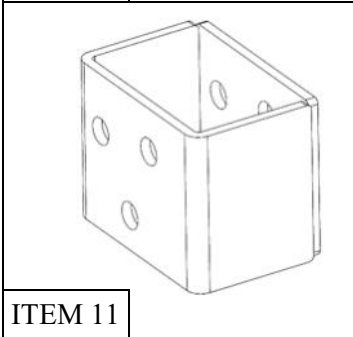

ITEM 11

### PROCEDURE

1. Remove contents from box, verify if all parts listed are present and free from damage.  
Carefully read and understand all instructions before attempting installation.  
**Failure to identify damage before installation could lead to a rejection of any claim.**

2. Open the hood of the vehicle and remove the plastic cover at the front using a pry tool. See **Figure 1**.
3. Remove the four bolts holding the grille in place. See **Figure 2**.
4. Remove 2 bolts attaching wheel well cover to filler panel. See **Figure 3**.

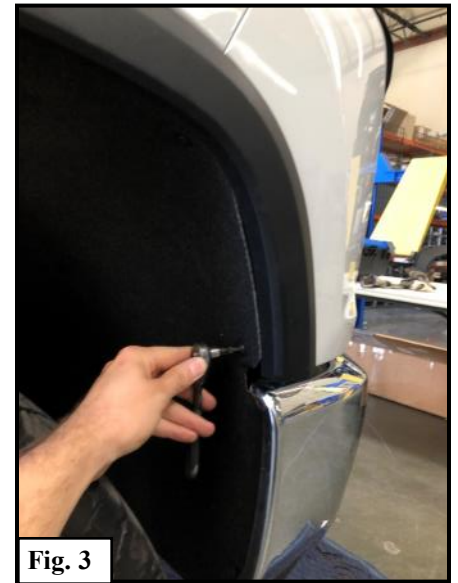
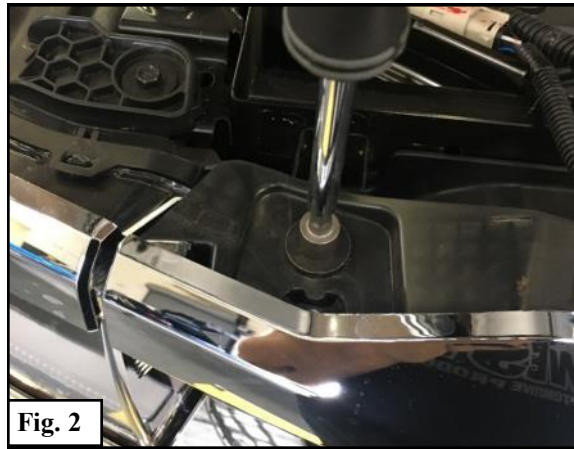

5. Pry off fenders to access the filler panel clips. See **Figure 4**.
6. Pry filler panel off removing any necessary bolts. See **Figure 5**.
7. Disconnect any electrical plugs and any bolts still attaching the grill to the vehicle. See **Figure 6**.
8. Pry remaining clips attaching the grill to the vehicle to remove the grille.

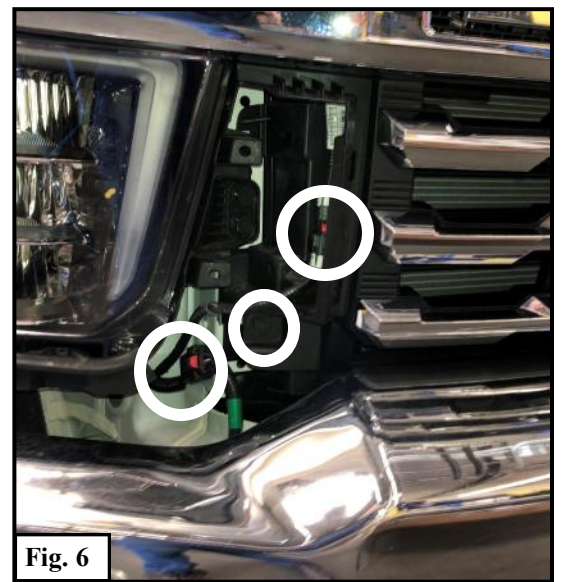
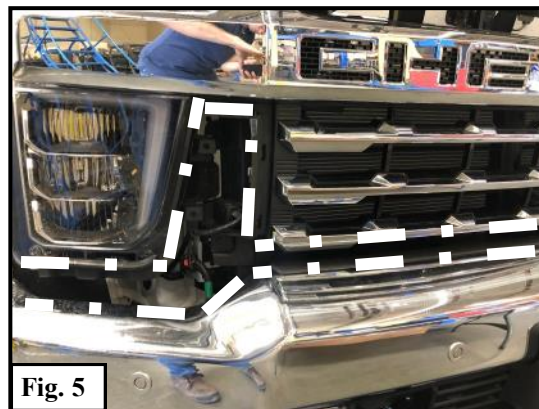
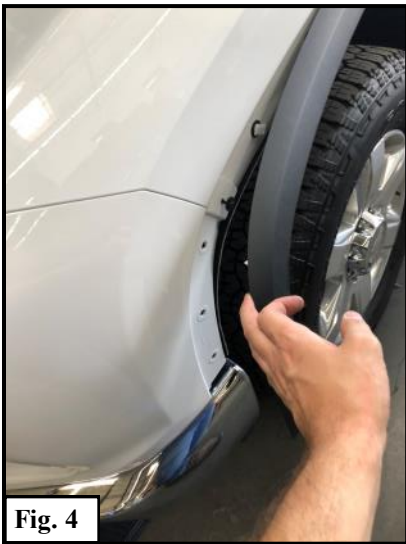

9. Remove 4 upper bumper bolts attaching the bumper to the frame and remove 2 bottom bolts attaching bumper arm to the frame. See **Figure 7 & 8**.

10. **Remove Bumper.**

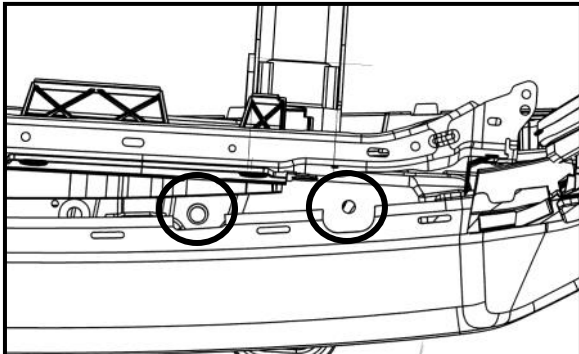

Fig. 7

Bolts will be exposed after removing the grille and lifting the plastic covering them

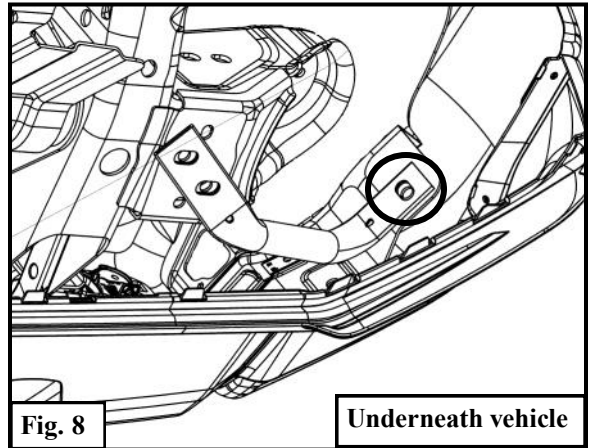

Fig. 8

Underneath vehicle

11. Locate the lower driver mounting brackets for the MAX winch tray. Using the supplied M12 hardware, loosely install the mounting brackets on to the frame. Slide the mounting bracket (3) in between the frame. The support bracket (5) goes under the frame. See **Figure 9 & 10**.

12. Repeat on the passenger side.



Fig. 9

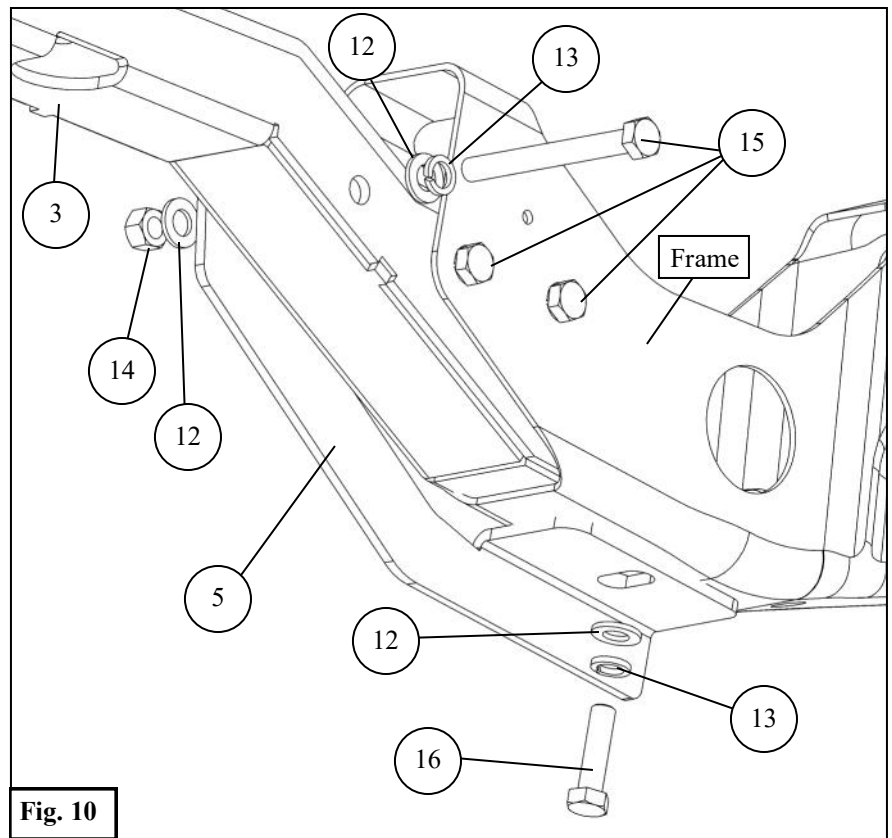
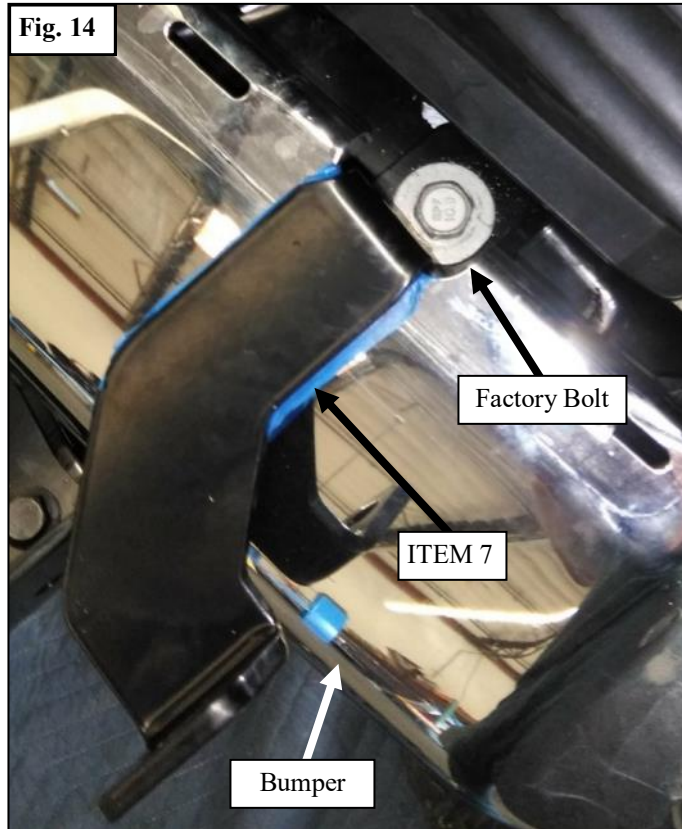

Fig. 10



## 2020-2023 Upper Strap "A"

13. Locate the upper support straps (7 and 8) for the grille guard. Loosely re-install the front bumper with the upper support straps. **Note: Trimming of tow pocket is required.** Trim out the tow hook pockets as necessary for the bracket clearance. The winch mount brackets will slide right through the previously trimmed tow hook pockets when reinstalling the bumper. Reconnect all electrical connections. The upper factory bumper bolts will be used for the upper support straps. Measure the distance between the mounting surfaces of the upper straps and ensure it is about 42.25". Torque to 50-55 ft-lbs.



**Fig. 15**

42.25 inches



## 2024+ Upper Strap "B"

14. Remove the plastic trim shown in **Figure 16**.
15. Locate the upper support straps "B" (**items 36 and 37**). Loosely re-install the front bumper with the upper support straps "B". Reconnect all electrical connections. The upper factory bumper bolts will be used for the upper support straps.
16. Cut the plastic trim removed in Step 15 so that the bolt can be accessed. The results should look like **Figure 16**.
17. Reinstall the plastic cover. See **Figure 16**.
18. Measure the distance between the mounting surfaces of the upper straps "B" and ensure it is about 42.25". Torque to 50-55 ft-lbs.



**Fig. 17**

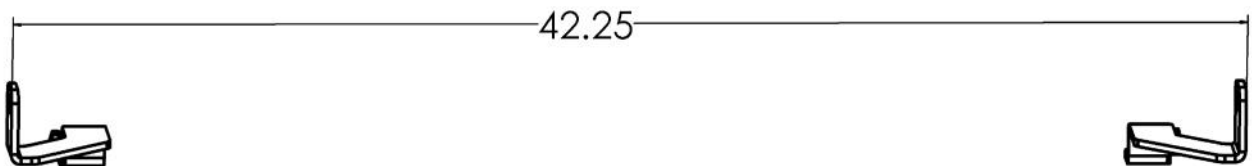

19. Re-install the front bumper and reconnect all electrical connections. *Note: Trimming of tow pocket is required.* Trim out the tow hook pockets as necessary for the bracket clearance. See Figure 18.

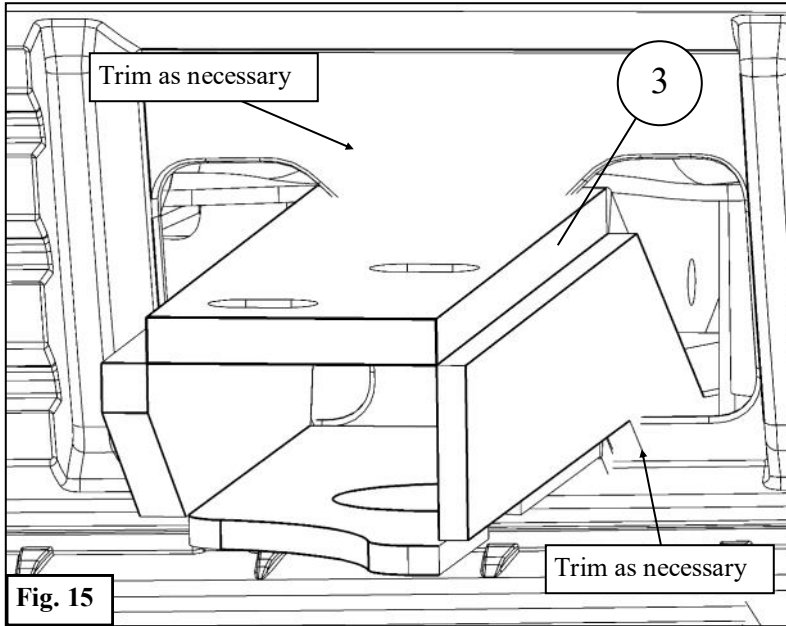

20. Locate the Winch Tray (2) and using the supplied flanged M12 Hardware, loosely assemble the Winch Tray to the mounting brackets. See **Figure 19**
21. If you are installing a winch, do so at this time. Adjust as needed and torque all hardware as specified: M12 to 50-55 ft-lbs.

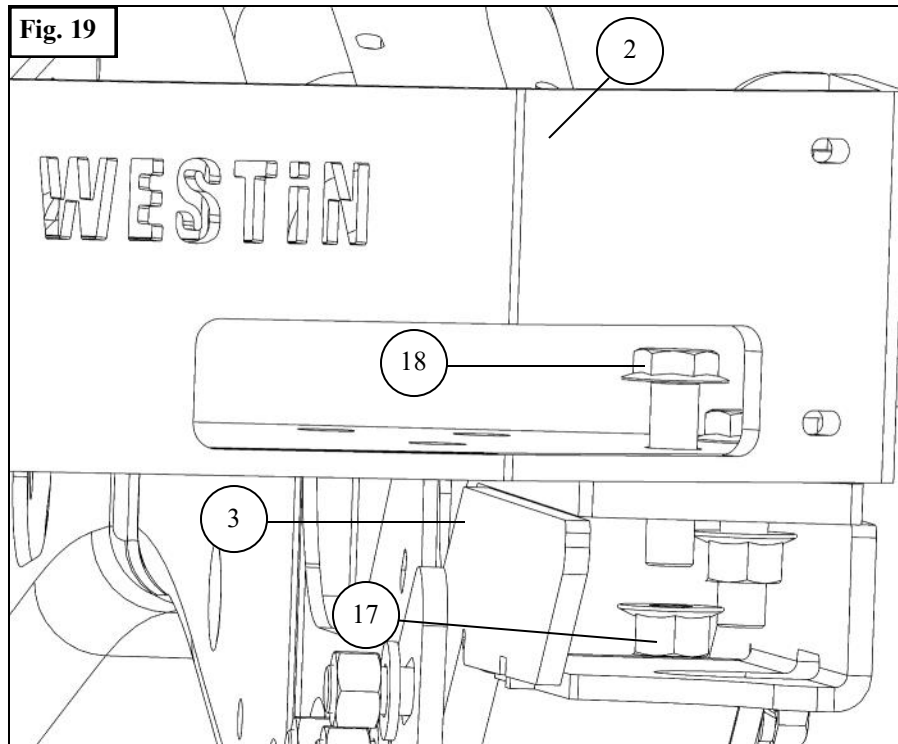

22. **If installing the HDX grille guard: Install winch first!** Locate the spacer blocks (9) and using supplied M12 hardware, mount the spacer blocks to the winch tray. See **Figure 20**

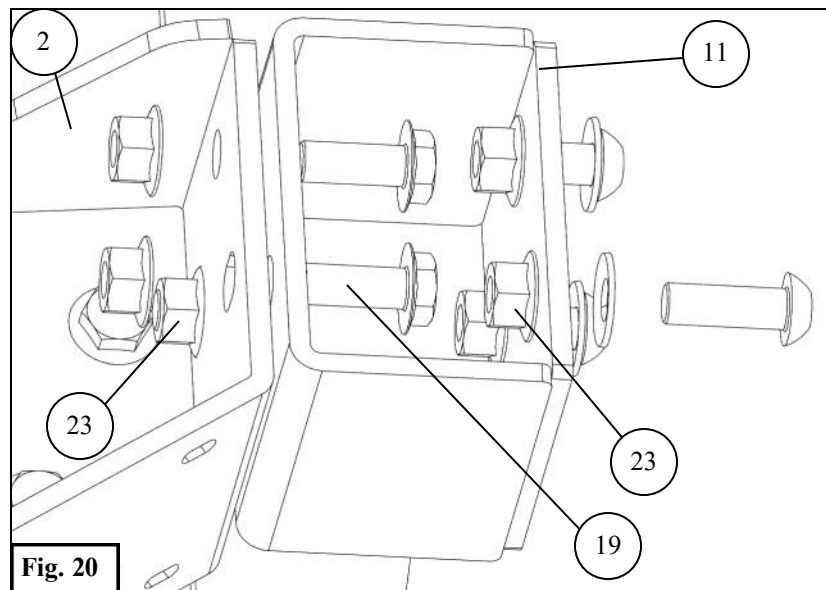



23. Reinstall the filler panel and grille.

24. With help, install the Grille Guard over the spacer blocks and previously installed upper support brackets. Using the supplied M12 hardware. See **Figures 21 & 22**.

25. Align as necessary and torque all hardware as specified: M12 to 50-55 ft-lbs., M10 to 30-35 ft-lbs.

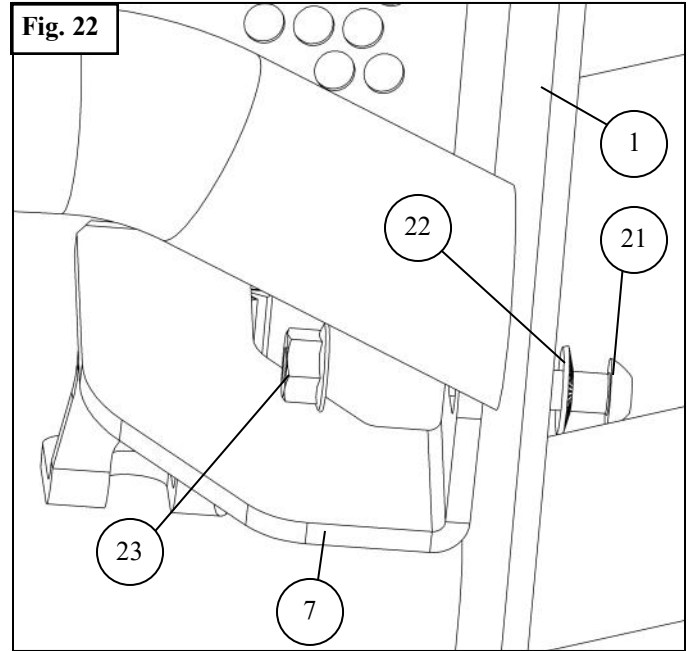
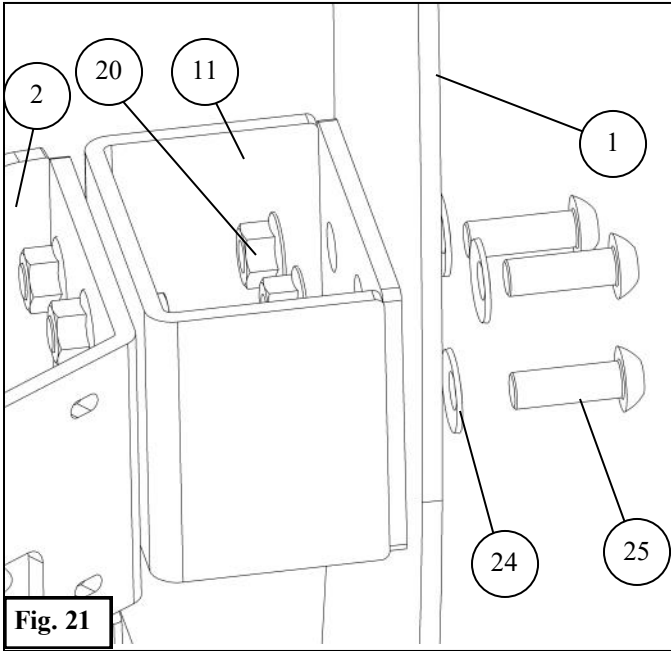

INSTALL COMPLETE



©2019 WESTIN AUTOMOTIVE PRODUCTS, INC. ALL RIGHTS RESERVED

#### CARE INSTRUCTIONS

- REGULAR WAXING IS RECOMMENDED. DO NOT USE ANY TYPE OF POLISH OR WAX THAT MAY CONTAIN ABRASIVES.
- STAINLESS STEEL PRODUCTS CAN BE CLEANED WITH MILD SOAP AND WATER. STAINLESS STEEL POLISH SHOULD BE USED TO POLISH SMALL SCRATCHES.
- GLOSS BLACK FINISHES SHOULD BE CLEANED WITH MILD SOAP AND WATER.

**WESTIN** Westin Automotive Products, Inc.  
320 W. Covina Blvd  
San Dimas, Ca. 91773

Thank You for choosing Westin products  
For Additional installation assistance please call  
Customer service (800) 793-7846  
[www.westinautomotive.com](http://www.westinautomotive.com)



## WARNING



Failure to follow these instructions could lead to death, personal injury, and / or property damage.

Failure to follow these instructions could lead to death, personal injury, and / or property damage.

### FASTENERS:

All Westin supplied fasteners must be utilized and installed in accordance with the installation instructions and apply torque to the specifications as defined. **DOUBLE CHECK ALL FASTENERS BEFORE INITIAL USE, AND PERIODICALLY IN THE FUTURE TO ENSURE PROPER FUNCTION AND SAFETY.**

### DRILLING:

Most Westin products do not require drilling for installation. If drilling is defined as required, use caution when drilling a vehicle. **FAILURE TO REVIEW AN AREA TO BE DRILLED MAY RESULT IN PERSONAL INJURY AND/OR INJURY TO OTHERS AS WELL AS VEHICLE DAMAGE.**

### EYE PROTECTION:

**ALWAYS WEAR SAFETY GLASSES OR GOGGLES DURING THE INSTALLATION PROCESS TO AVOID PERSONAL INJURY.**

### MAXIMUM TOWING/CARRYING CAPACITY: (if applicable)

The Westin Receiver Hitches will have a visible tow rating label affixed directly on the product. User should never exceed the vehicle manufacturers maximum tow and weight rating regardless of the capacity of the hitch. **FAILURE TO FOLLOW THESE GUIDELINES WILL VOID THE WESTIN WARRANTY AND MAY RESULT IN PERSONAL INJURY AND/OR INJURY TO OTHERS AS WELL AS VEHICLE DAMAGE.**

### FOR CALIFORNIA RESIDENTS ONLY-PROP 65 WARNING:

Some products may contain chemicals such as DEHP, which can cause cancer, birth defects or other reproductive harm. For more info go to [www.p65warnings.ca.gov](http://www.p65warnings.ca.gov)



Westin Automotive Products, Inc.  
320 W. Covina Blvd  
San Dimas, Ca. 91773

Thank You for choosing Westin products  
For Additional installation assistance please call  
Customer service (800) 793-7846  
[www.westinautomotive.com](http://www.westinautomotive.com)