

# INSTALLATION INSTRUCTIONS

## XTS ROCK SLIDER



APPLICATION:  
2005-2023 TOYOTA TACOMA (DOUBLE CAB SHORT BED)

PART NUMBER:  
42-14205

CONTENT			
ITEM	QUANTITY	DESCRIPTION	TOOLS NEEDED
1	1	DRIVER XTS ROCK SLIDER	18MM SOCKET
2	1	PASSENGER XTS ROCK SLIDER	18MM WRENCH
3	2	FRONT SPACER PLATE	14MM SOCKET
4	2	FRONT NUT PLATE	14MM WRENCH
5	6	M12 40MM LONG HEX HEAD SCREW	12MM SOCKET
6	4	M12 45MM LONG HEX HEAD SCREW	12MM WRENCH
7	16	M12 FLAT WASHER	10MM SOCKET
8	6	M12 SERRATED FLANGE LOCKNUT	10MM WRENCH
9	4	M12 SPLIT LOCK WASHER	RATCHET
10	2	M10 HEX HEAD SCREW	
11	2	M10 FLAT WASHER	
12	2	M10 SPLIT LOCK WASHER	

ANTI-SEIZE LUBRICANT MUST BE USED ON ALL STAINLESS STEEL FASTENERS TO PREVENT THREAD DAMAGE AND GALLING

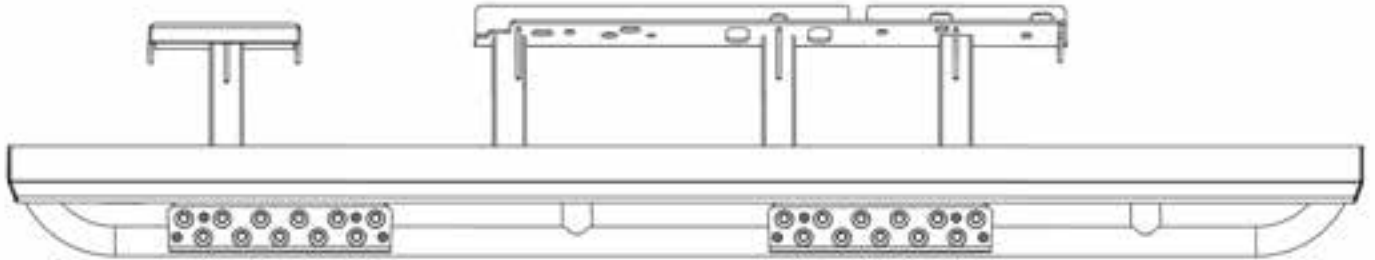

ITEM 1

Driver side shown



ITEM 3

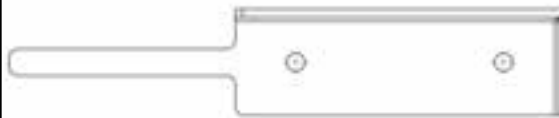

ITEM 4

## PROCEDURE

1. Remove contents from box, verify if all parts listed are present and free from damage. Carefully read and understand all instructions before attempting installation.  
**Failure to identify damage before installation could lead to a rejection of any claim.**
2. Some vehicles may have covers located on the inside of the frame rails, remove it using a 12MM socket (Fig 1). Remove the brake line bracket using a 10MM socket (Fig 2).
3. Remove the oem frame bolt located in (Fig 3) using a 14MM socket.
4. With assistance, mount the rock slider assembly (Items 1 & 2) to the frame rail and use a 16MM socket to loosely screw one M10 Hex Head Screw, one M10 Split Lock Washer, and one M10 Flat Washer (Items 10-12) on the bottom side of the frame rail (Fig 3).
5. With the rock slider loosely installed, place the Front Spacer Plate (Item 3) between the forwardmost mount of the rock slider and the frame rail. **Note: The wide section of the front spacer plate should point towards the rear of the vehicle (Fig 4).**



6. **Figure 5** shows the locations of where the M12 hardware goes to mount the rock slider assembly onto the vehicle's frame.
7. Secure the rock slider to the vehicle by inserting three M12 40MM Long Hex Head Screws (Item 5) into the locations shown below in **Fig 5-7**. **Note: The mounting hole in Figure 8 may be obstructed by the brake lines within the frame rail. If this occurs orient the 40MM long hex head screw so the head of the bolt is on the inside of the frame. (Fig 9)**
8. The three M12 40MM long head head screws each require two M12 Flat Washers (one on the inside and one on the outside of the vehicle frame) and one M12 Serrated Flange Locknut. Use a 18MM socket to tighten all M12 hardware.

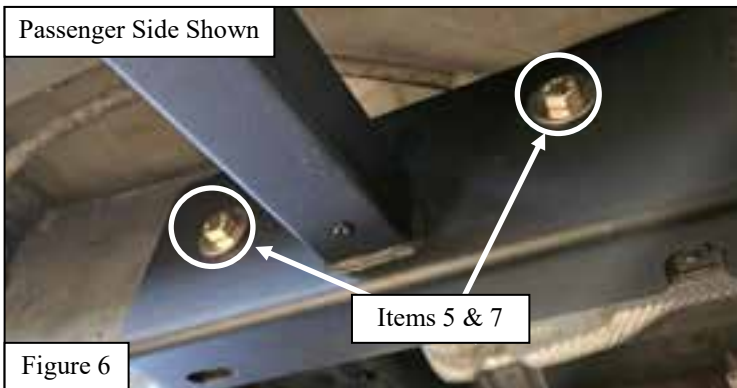
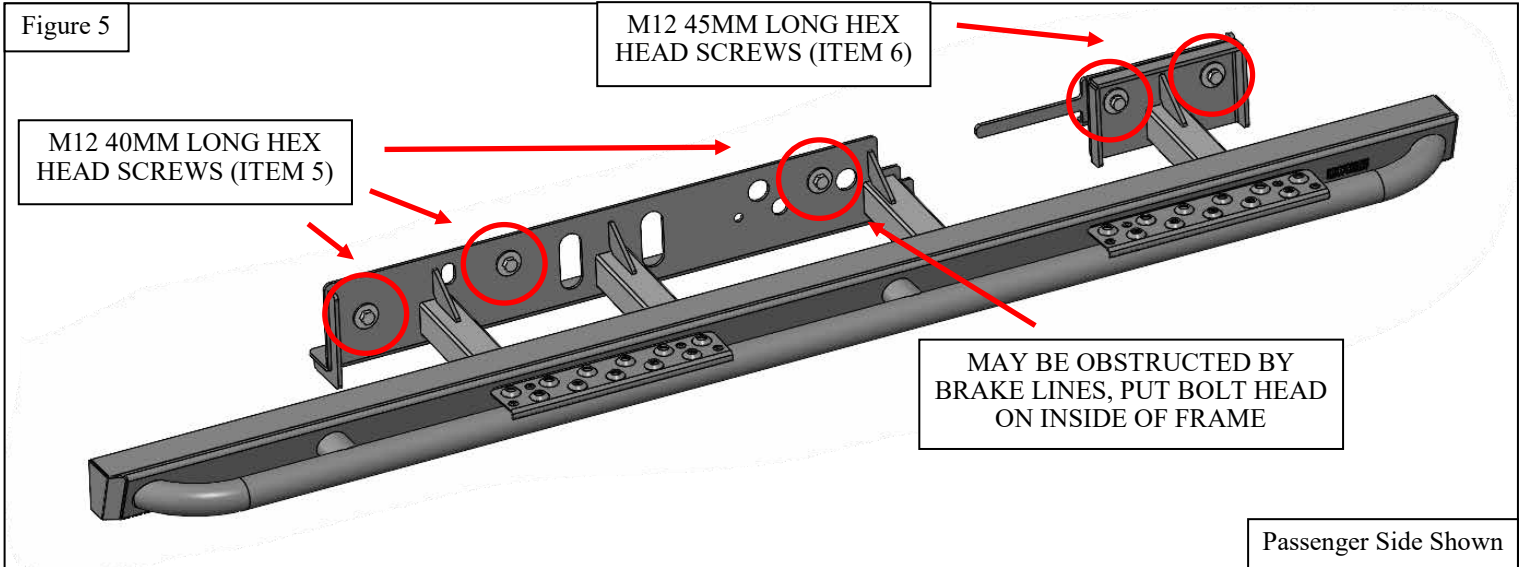



9. Place the Front Nut Plate (Item 4) on the inside of the frame rail (**Fig 10-11**). Use two M12 45MM Hex Head Screws, two M12 Split Lock Washers and two M12 Flat Washers to bolt the front of the rock slider to the vehicle (**Fig 12**).

Note: Repeat process for the other side of the vehicle and make sure all bolts are fully tightened. Reinstall the brake line brackets and inner frame covers.

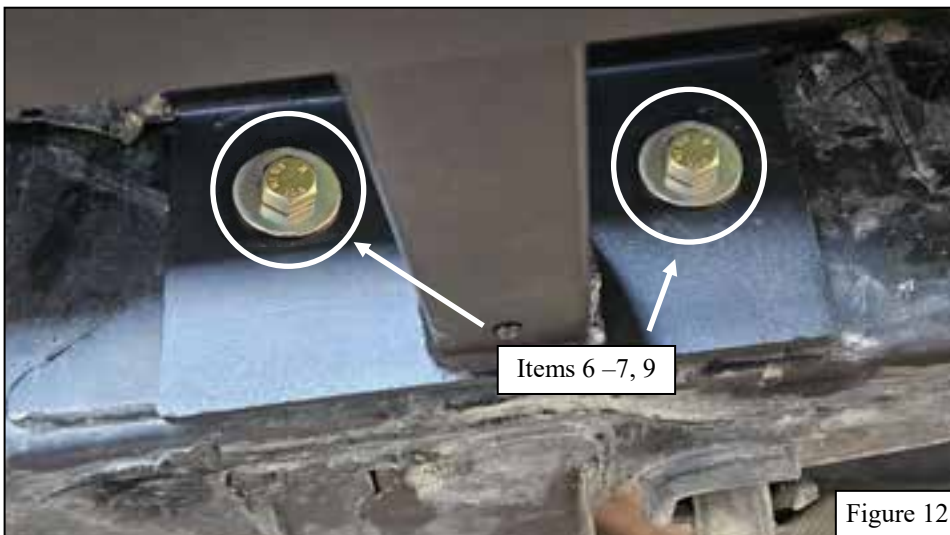
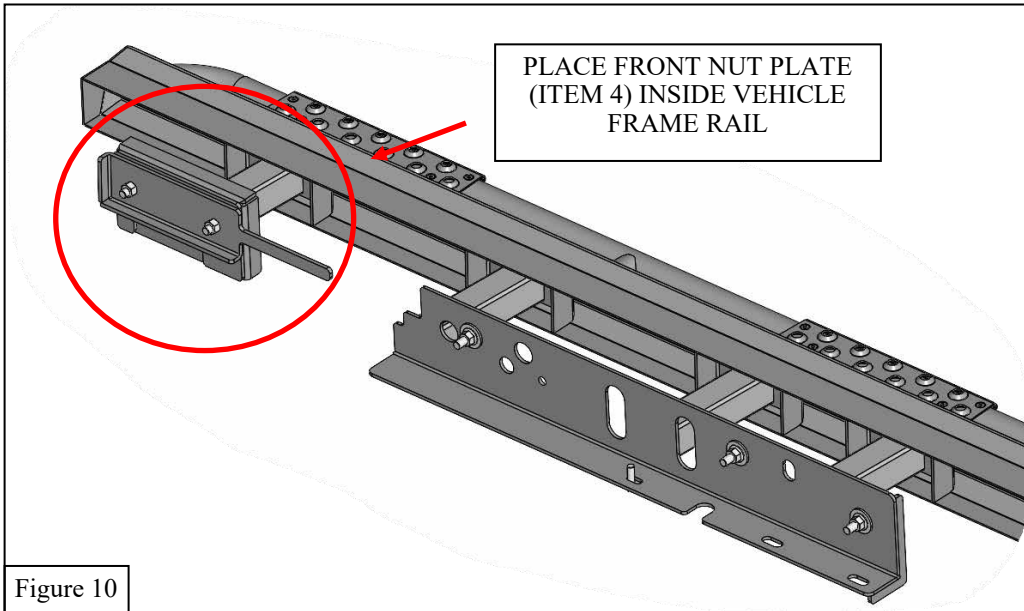

INSTALLATION COMPLETE



CARE INSTRUCTIONS

- REGULAR WAXING IS RECOMMENDED. DO NOT USE ANY TYPE OF POLISH OR WAX THAT MAY CONTAIN ABRASIVES.
- STAINLESS STEEL PRODUCTS CAN BE CLEANED WITH MILD SOAP AND WATER. STAINLESS STEEL POLISH SHOULD BE USED TO POLISH SMALL SCRATCHES.
- GLOSS BLACK FINISHES SHOULD BE CLEANED WITH MILD SOAP AND WATER.

**WESTIN** Westin Automotive Products, Inc.  
320 W. Covina Blvd  
San Dimas, Ca. 91773

P.N.: 75-4214205-REVA

ECO #: W23-0103

Thank you for choosing Westin products  
for additional installation assistance please call  
Customer Service (800) 793-7846

[www.westinautomotive.com](http://www.westinautomotive.com)

DATE: 9/12/2024



## WARNING



Failure to follow these instructions could lead to death, personal injury, and / or property damage.

Failure to follow these instructions could lead to death, personal injury, and / or property damage.

### FASTENERS:

All Westin supplied fasteners must be utilized and installed in accordance with the installation instructions and apply torque to the specifications as defined. **DOUBLE CHECK ALL FASTENERS BEFORE INITIAL USE, AND PERIODICALLY IN THE FUTURE TO ENSURE PROPER FUNCTION AND SAFETY.**

### DRILLING:

Most Westin products do not require drilling for installation. If drilling is defined as required, use caution when drilling a vehicle. **FAILURE TO REVIEW AN AREA TO BE DRILLED MAY RESULT IN PERSONAL INJURY AND/OR INJURY TO OTHERS AS WELL AS VEHICLE DAMAGE.**

### EYE PROTECTION:

**ALWAYS WEAR SAFETY GLASSES OR GOGGLES DURING THE INSTALLATION PROCESS TO AVOID PERSONAL INJURY.**

### MAXIMUM TOWING/CARRYING CAPACITY: (if applicable)

The Westin Receiver Hitches will have a visible tow rating label affixed directly on the product. User should never exceed the vehicle manufacturers maximum tow and weight rating regardless of the capacity of the hitch. **FAILURE TO FOLLOW THESE GUIDELINES WILL VOID THE WESTIN WARRANTY AND MAY RESULT IN PERSONAL INJURY AND/OR INJURY TO OTHERS AS WELL AS VEHICLE DAMAGE.**

### FOR CALIFORNIA RESIDENTS ONLY-PROP 65 WARNING:

Some products may contain chemicals such as DEHP, which can cause cancer, birth defects or other reproductive harm. For more info go to [www.p65warnings.ca.gov](http://www.p65warnings.ca.gov)



Westin Automotive Products, Inc.  
320 W. Covina Blvd  
San Dimas, Ca. 91773