

INSTALLATION INSTRUCTIONS



XTS Overhead Light Bar

APPLICATION:
Ford Bronco 2021-2023 (Excl. Bronco Sport)

PART NUMBER:
37-711255

CONTENT			
ITEM	QUANTITY	DESCRIPTION	TOOLS NEEDED
1	1	XTS OVERHEAD LIGHT BAR	10MM SOCKET
2	1	DRIVER SIDE SPACER PLATE	10MM WRENCH
3	1	PASSENGER SIDE SPACER PLATE	RATCHET
4	4	M6 HEX NUTS	TORQUE WRENCH
5	4	M6 SPLIT LOCK WASHER	
6	4	M6 FLAT WASHER	

ANTI-SEIZE LUBRICANT MUST BE USED ON ALL STAINLESS STEEL FASTENERS TO PREVENT THREAD DAMAGE AND GALLING

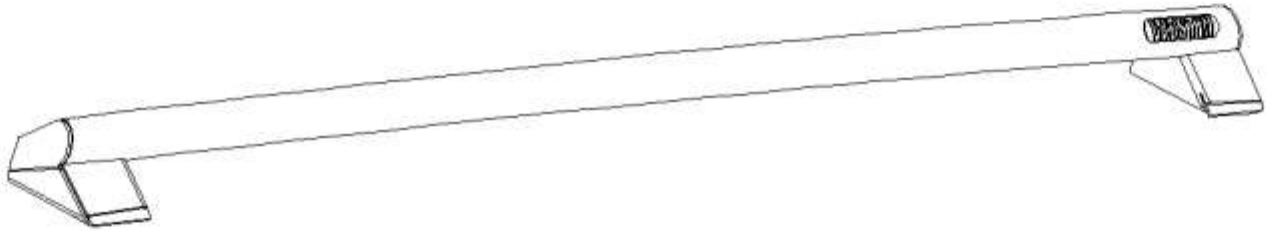

ITEM 1

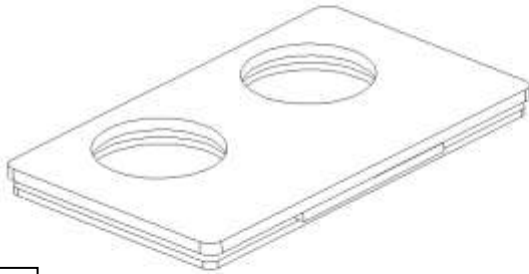

ITEM 2

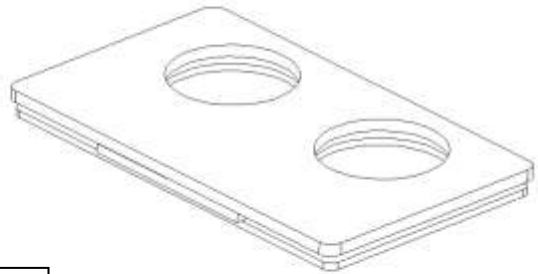

ITEM 3

PROCEDURE

1. Remove contents from box, verify if all parts listed are present and free from damage.
Carefully read and understand all instructions before attempting installation.
Failure to identify damage before installation could lead to a rejection of any claim.
2. Starting on the driver's side, remove the plastic caps above the windshield to expose the roof mounting locations. Remove the factory hardware and the plastic cover then replace it with Driver Side Spacer Plate (Item 2). See **Figure 1**. *Note: The factory hardware retaining the plastic covers may be reused.*
3. Repeat **Step 2** on passenger side with Passenger Side Spacer Plate (Item 3).

4. If you are installing any sort of post mount lights or light bar, do so at this time per the manufacture's instructions using the light bar mounting locations.
5. Assemble the XTS Overhead Light Bar onto the spacer plates and loosely attach it with the provided M6 hardware (**Items 4-6**). See **Figure 2** for reference.
6. Align and adjust the light bar as needed. Tighten and torque all M6 hardware to 7.80 ft-lbs.

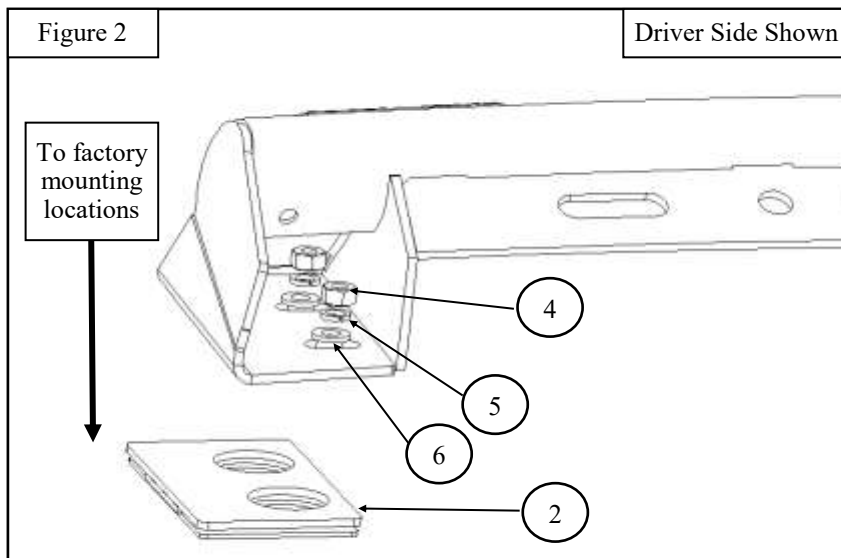

INSTALLATION COMPLETE





WARNING



Failure to follow these instructions could lead to death, personal injury, and / or property damage.

Failure to follow these instructions could lead to death, personal injury, and / or property damage.

FASTENERS:

All Westin supplied fasteners must be utilized and installed in accordance with the installation instructions and apply torque to the specifications as defined. **DOUBLE CHECK ALL FASTENERS BEFORE INITIAL USE, AND PERIODICALLY IN THE FUTURE TO ENSURE PROPER FUNCTION AND SAFETY.**

DRILLING:

Most Westin products do not require drilling for installation. If drilling is defined as required, use caution when drilling a vehicle. **FAILURE TO REVIEW AN AREA TO BE DRILLED MAY RESULT IN PERSONAL INJURY AND/OR INJURY TO OTHERS AS WELL AS VEHICLE DAMAGE.**

EYE PROTECTION:

ALWAYS WEAR SAFETY GLASSES OR GOGGLES DURING THE INSTALLATION PROCESS TO AVOID PERSONAL INJURY.

MAXIMUM TOWING/CARRYING CAPACITY: (if applicable)

The Westin Receiver Hitches will have a visible tow rating label affixed directly on the product. User should never exceed the vehicle manufacturers maximum tow and weight rating regardless of the capacity of the hitch. **FAILURE TO FOLLOW THESE GUIDELINES WILL VOID THE WESTIN WARRANTY AND MAY RESULT IN PERSONAL INJURY AND/OR INJURY TO OTHERS AS WELL AS VEHICLE DAMAGE.**

FOR CALIFORNIA RESIDENTS ONLY-PROP 65 WARNING:

Some products may contain chemicals such as DEHP, which can cause cancer, birth defects or other reproductive harm. For more info go to www.p65warnings.ca.gov



Westin Automotive Products, Inc.
320 W. Covina Blvd
San Dimas, Ca. 91773