



INSTALLATION INSTRUCTIONS

PRO-E ELECTRIC RUNNING BOARDS

APPLICATION:
Toyota Tundra Double Cab 2007-2021

PART NUMBER:
29-23245



Estimated Time to Complete Product Installation: 3 - 4 Hours

CONTENTS

- Component List Page 02
- Electrical Component Installation Procedure Page 05
- Mechanical Component Installation Procedure Page 11
- Product Warranty and Warnings Page 18

COMPONENT LIST

| ITEM | QUANTITY | DESCRIPTION | TOOLS NEEDED |
|------|----------|--|------------------|
| 1 | 2 | RUNNING BOARD ASSEMBLY | 5MM ALLEN WRENCH |
| 2 | 1 | DRIVER SIDE FRONT MOTOR LINKAGE | |
| 3 | 1 | PASSENGER SIDE FRONT MOTOR LINKAGE | 13MM SOCKET |
| 4 | 1 | DRIVER SIDE REAR MOTOR LINKAGE | 13MM WRENCH |
| 5 | 1 | PASSENGER SIDE REAR MOTOR LINKAGE | WIRE STRIPPER |
| 6 | 1 | CONTROL MODULE ASSEMBLY | ELECTRICAL TAPE |
| 7 | 25 | ZIP TIES | RATCHET |
| 8 | 1 | POWER BOARD MANUAL SWITCH | TORQUE WRENCH |
| 9 | 2 | MAGNETIC INDUCTION MODULE | |
| 10 | 4 | DOOR MAGNET | |
| 11 | 4 | LED LIGHTS | |
| 12 | 1 | WIRING HARNESS | |
| 13 | 2 | FUSE | |
| 14 | 8 | LONG M8 HEX FLANGE BOLT | |
| 15 | 2 | SHORT M8 HEX FLANGE BOLT | |
| 16 | 8 | M6 HEX SOCKET CAP SCREW | |
| 17 | 1 | REAR REINFORCEMENT BRACKET PLATE LEFT | |
| 18 | 1 | REAR REINFORCEMENT BRACKET PLATE RIGHT | |

Remove the components from the box, verify if all parts listed are present and free from damage.

Carefully read and understand all instructions before attempting installation.

Note that failure to identify damage before installation could lead to a rejection of any claim.

Note: It is recommended that anti-seize lubricant is used on all stainless steel fasteners to prevent thread damage and galling.

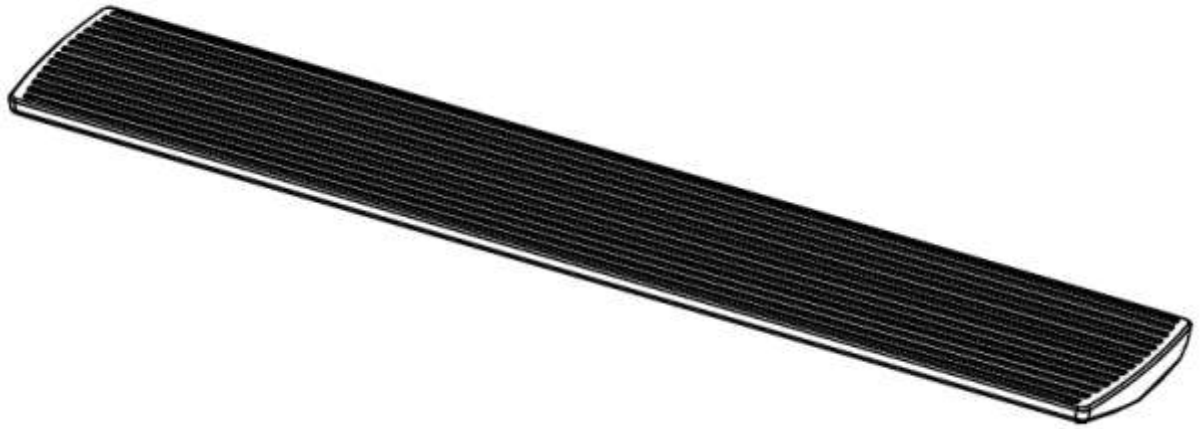

ITEM 1

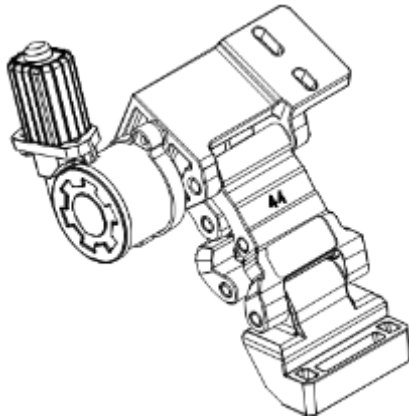

ITEM 2

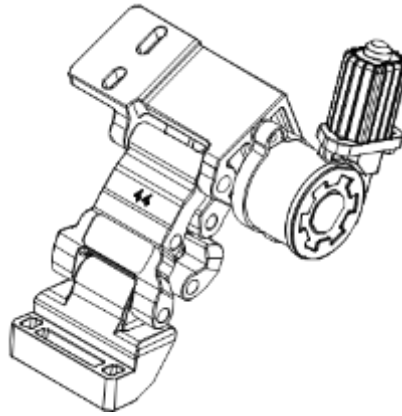

ITEM 3

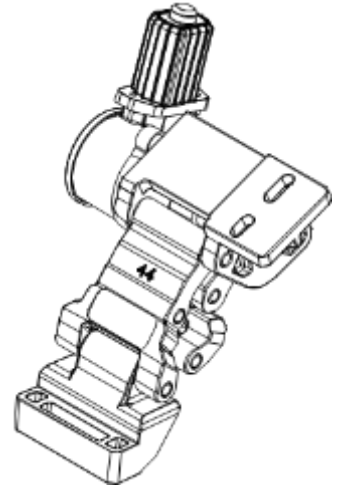

ITEM 4

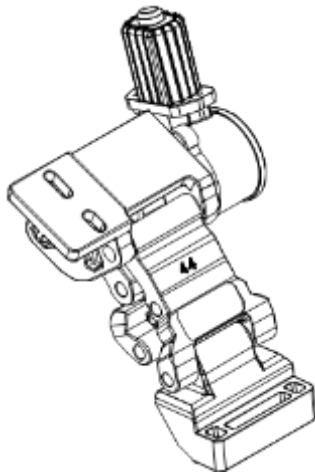

ITEM 5

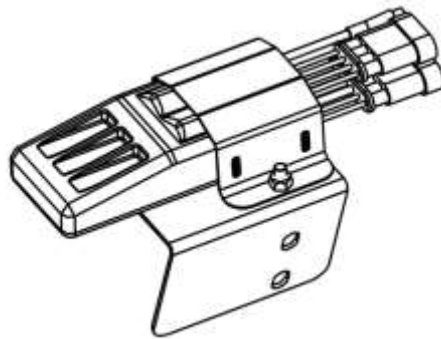

ITEM 6



ITEM 7

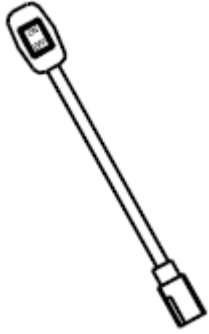

ITEM 8

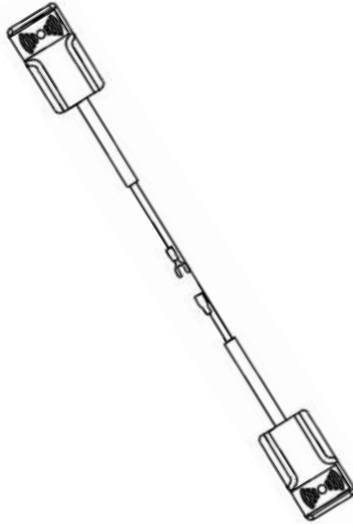

ITEM 9



ITEM 10



ITEM 13

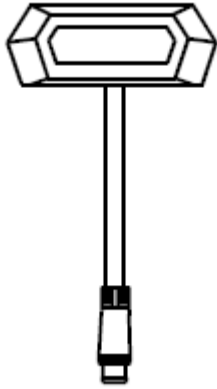

ITEM 11



ITEM 12



ITEM 17



ITEM 18

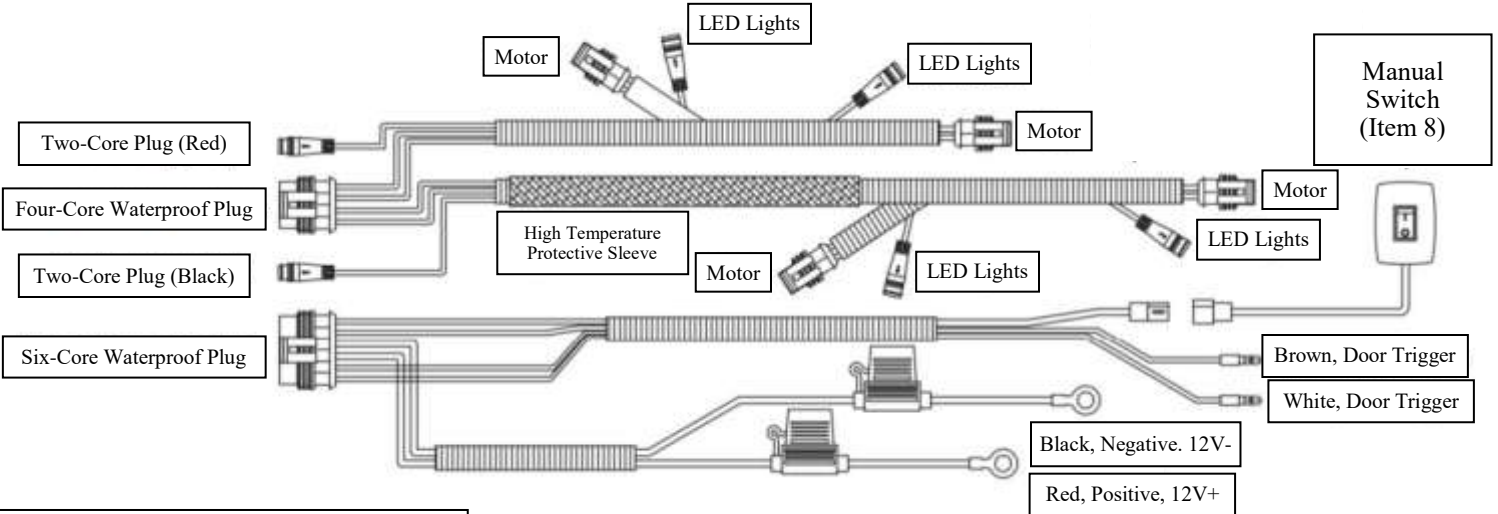

ITEM 12: Wiring Harness Leads

ELECTRICAL COMPONENT INSTALLATION PROCEDURE

1. Begin by disconnecting the battery from the vehicle. Start with the negative battery terminal, then the positive battery terminal.
2. On both the driver and passenger side of the vehicle, remove the front door sill trim panel and the B-Pillar trim panel by carefully pulling on the panels enough to release them from the plastic retaining clips. For the B-Pillars you may need to remove the rear seat handles and seatbelt bolt to fully remove B-Pillars. (See **Figures 1 through 5** for reference).





3. With the B-pillar panels removed, on the passenger side pull carpet back and identify the rubber grommet located under the passenger seat. Remove this grommet and drill or cut an opening for the wires to pass through. (See **Figures 6 through 8** for reference).
4. From under the vehicle feed the four wires, door trigger signal wires (**White & Brown**) and the two manual switch wires (**Two Black**) into the cab and through the hole in rubber grommet. Then place the grommet back into place. (See **Figures 8 & 9** for reference). *Note: To avoid possible water intrusion, it is recommended to use RTV Silicone Adhesive to seal the opening once the wires are fed into the cab.*
5. Route the brown door trigger wire to the passenger side B-Pillar, and the white door trigger wire (White) and manual switch wires (**Two Black**) under the front passenger carpet, through the center console. (See **Figure 10 & 11** for reference)



6. You now need to ground the induction module wires. locate the seat belt assembly on the passenger's side behind the removed B-Pillar panels and loosen the bolt shown. Locate the magnetic induction module (Item 9) and mount the ground wire fork under the bolt of the seat belt assembly to provide a ground connection. Once grounded, connect the snap-in bullet connector on the module to the brown trigger wire and neatly tuck wires away so it sits neatly under side door sill panel. (See **Figure 7 & 8** for reference). It is also important to route the induction modules underneath the door seals so they rest in the front and rear door jamb. (you will stick these in place in later steps)
7. Repeat **Step 6** to ground the driver side induction module to the driver side B-pillar and connect the bullet connector to the white trigger wire that was previously routed through the center console, at this time route the white wire under the driver side floor carpet to the driver side B-Pillar so it is hidden.

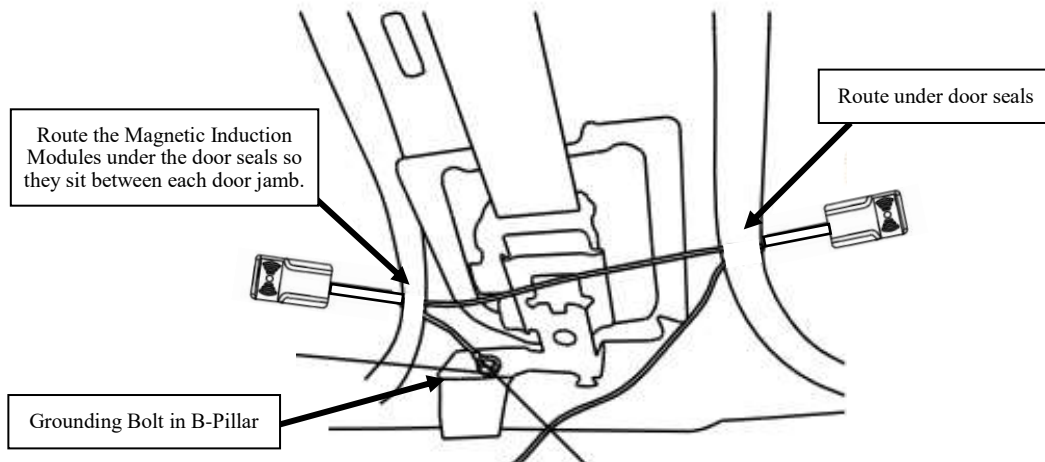
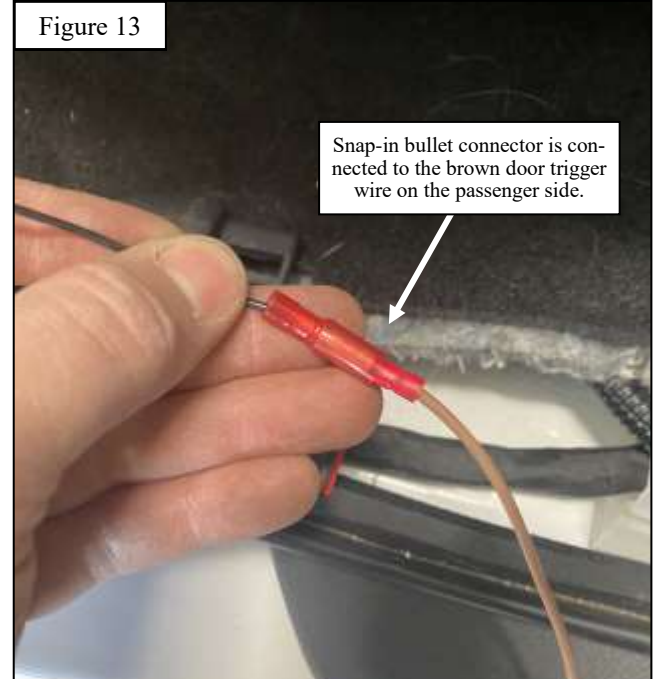
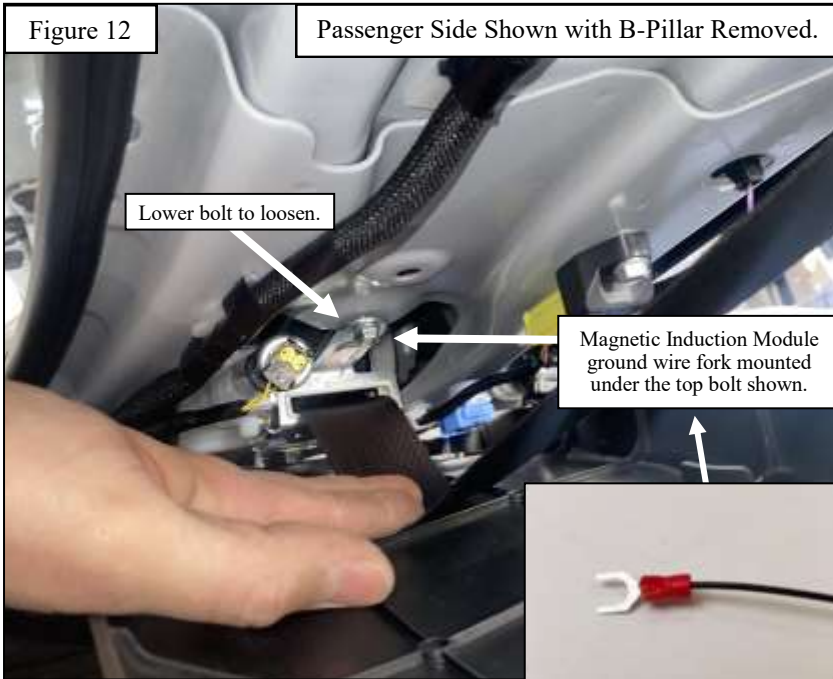
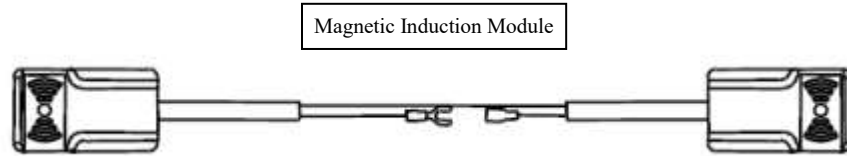

8. You are now ready to stick the induction modules and magnets to the B-Pillar and doors. Before doing this clean both surfaces with a damp rag with 50/50 mix of isopropyl alcohol and water.
9. Once the surface is completely dry, remove backing from the front magnetic induction module and place it 2” under the front passenger B-pillar door striker located in the front passenger side door jamb and “stick it in place”. (See **figure 14** for reference)
10. For the front passenger magnet position, use a ruler and measure 2” down from the center of the door latch as a reference point. Prepare the surface by cleaning with a damp rag and 50/50 mix of isopropyl alcohol and water and proceed to place the magnet onto the door. (See **figure 15** for reference)

Important: For these steps you need to make sure the magnetic induction modules line up with the door magnets when the door is closed, failure to do this will mean the step bar will not drop when door is opened.



11. For the rear passenger induction module position, use a measuring tape and measure 5" up from the door hinge support for a reference point. Clean both surfaces with a damp rag with 50/50 mix of isopropyl alcohol and water and proceed to stick the magnetic induction module in place. (See **figure 16** for reference)
12. For the rear passenger door magnet, position it 5" up from the same the door hinge support so it will line up with induction module when door is closed. (See **figure 17** for reference)
13. Repeat **Steps 8 through 12** on the driver side, mounting the remaining magnetic induction modules and door magnets.

Important: For these steps you need to make sure the magnetic induction modules line up with the door magnets when door is closed, failure to do this will mean the step bar will not drop when door is opened.

If the boards are not deploying once all of the wiring is connected, inspect and ensure that the magnets align with their corresponding module sensor.



14. Locate the manual switch (Item 8) and connect it to the two black manual switch wires that were previously routed through the center console and into the driver side.
15. You can now stick the manual switch to the driver side lower dash panel. To do this first prepare the desired mounting surface by using a damp rag with a 50/50 mix of isopropyl alcohol and water to clean the surface. Once the surface is dry, remove the double sided tape and stick the manual switch to the desired location. Neatly tuck or zip tie the extra wiring away so that the switch cannot be tugged or pulled accidentally. (See **figure 18** for reference).
16. Moving back to the wiring underneath the vehicle, route the two fused power wires towards the front of the vehicle. Pull back the driver side fender liner and feed the fused power wires into the engine compartment and leave them disconnected from the battery. (See **Figures 19 & 20** for reference).

Manual Switch

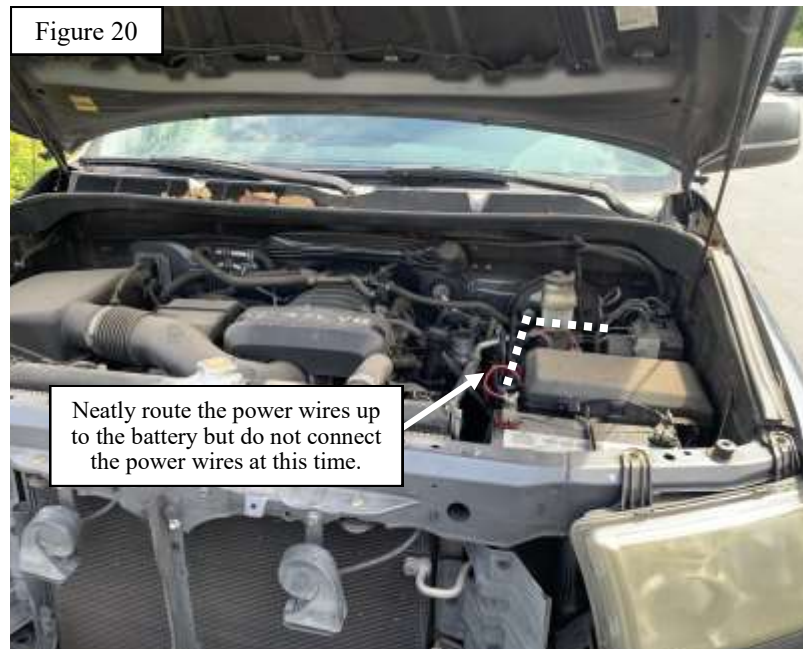
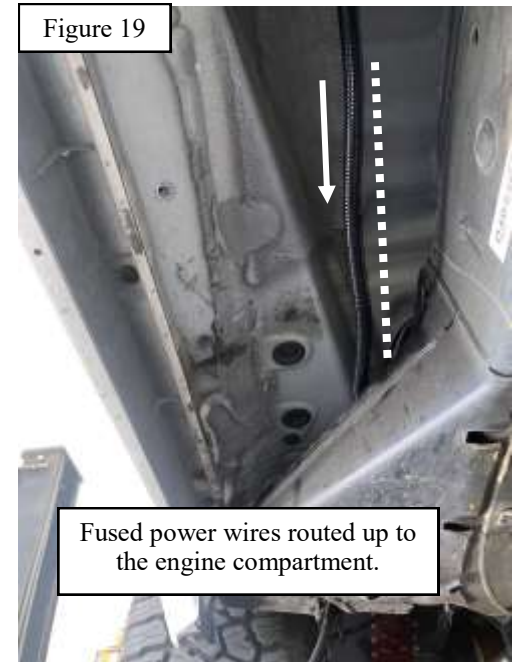

MECHANICAL COMPONENT INSTALLATION PROCEDURE

17. Starting on the driver side of the vehicle, locate the mounting locations with factory bolts preinstalled in them. Remove the factory bolts from the threaded holes. (See **Figures 21 & 22** for reference). **Note:** *The factory bolts will not be reused.*

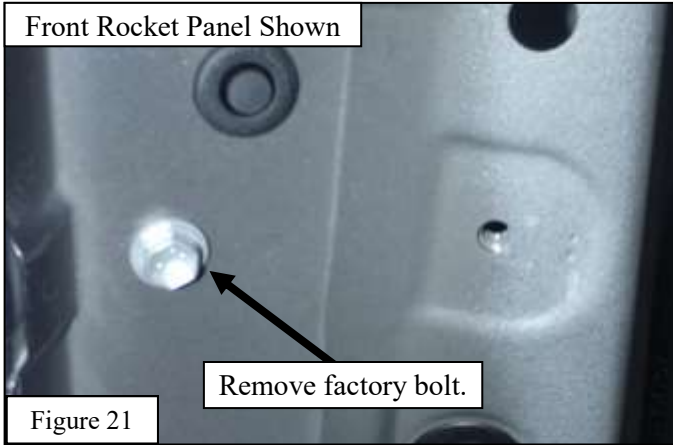

18. Now you are ready to install the motor linkages. Begin on the driver side of the vehicle, loosely install the driver front motor linkage (Item 2) to the front rocker panel mounting location using the supplied M8 hardware as shown in **Figures 24**. Please refer to **Figure 23** for bracket orientation and locations.

Note: *The motor linkages are etched, and call out the corresponding mounting location to help aid with linkage placement.*

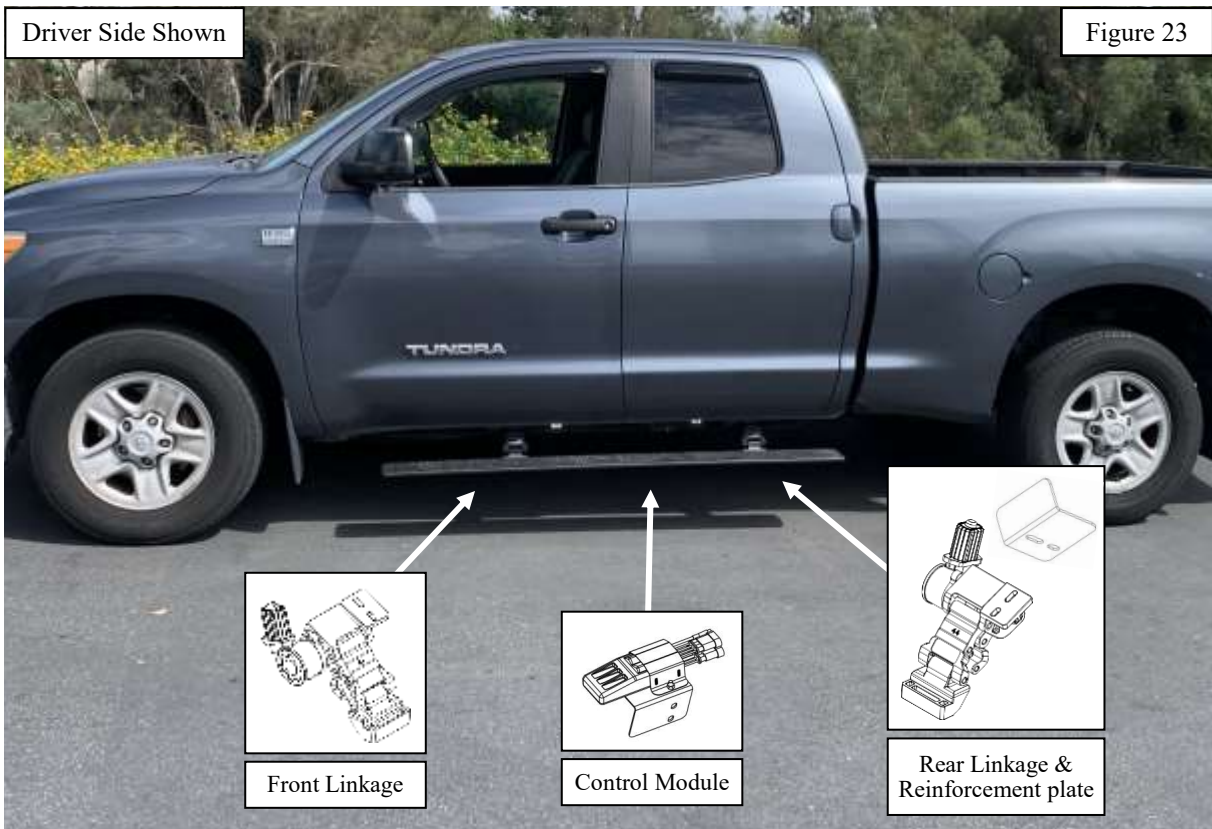

19. Loosely install the driver rear motor linkage (Item 4) and the rear reinforcement bracket plate (Item 17/18) to the rear rocker panel mounting location using the supplied M8 hardware as shown in **Figure 25**. Please refer to **Figure 23** for bracket orientation and locations. **Repeat steps 18 & 19 for passenger side motor linkages and reinforcement plate.**

Note: The motor linkages are etched, and call out the corresponding mounting location to help aid with linkage placement.

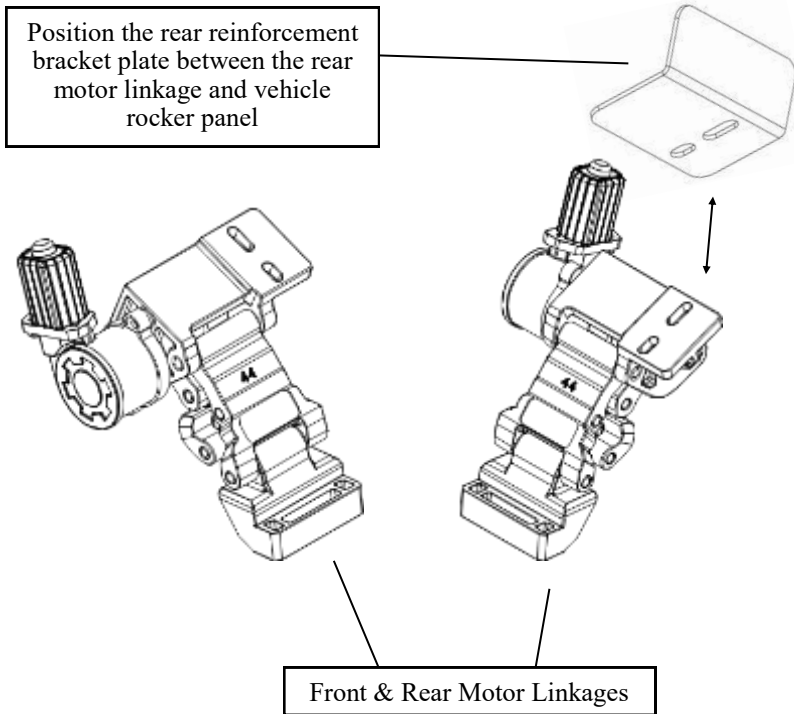

20. Loosely install the control module assembly (Item 6) to the center mounting location on the rocker panel using the supplied M8 hardware (See **Figure 26** for reference).

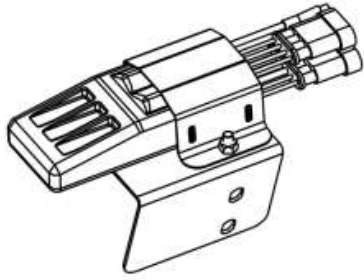

Control Module Assembly



Figure 26

21. With assistance, loosely install one of the running board assemblies (Item 1) to the passenger side of the vehicle. Position the board on the front and rear motor assembly bases, and align the sliding T-Nut on the running board with the corresponding slots on the front and rear motor bases. Once the T-Nuts are aligned, slightly rotate the running board to allow the T-Nuts to set into the slots on the motor bases. (See **Figure 27 & 28** for reference).
22. Repeat **Step 21** for the driver side of the vehicle.
23. Align and adjust the both the motor linkage assemblies and the driver and passenger side running boards to the desired positioning. Use the supplied hex M6 socket cap screws (Item 16) to secure the running board to the motor linkage arms.
24. Once all components have been adjusted to the desired positioning, fully tighten and torque all hardware as specified: M6 hardware to 8-9 ft-lbs., M8 hardware to 15-18 ft-lbs.,

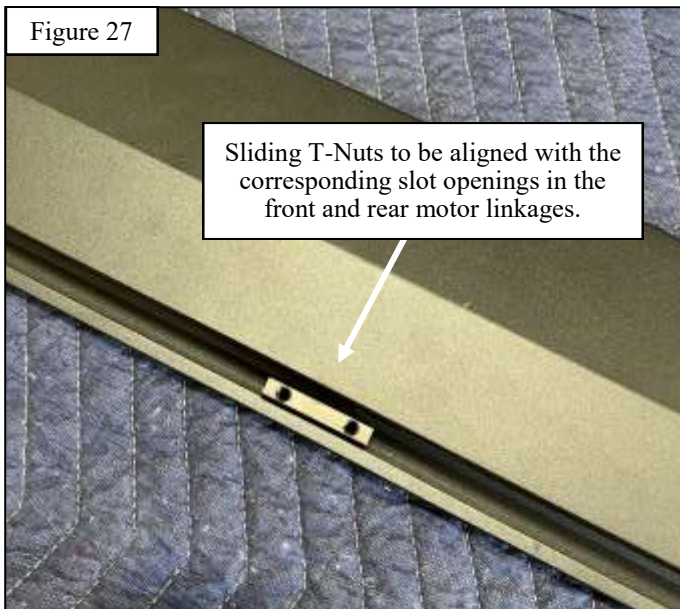

Figure 27

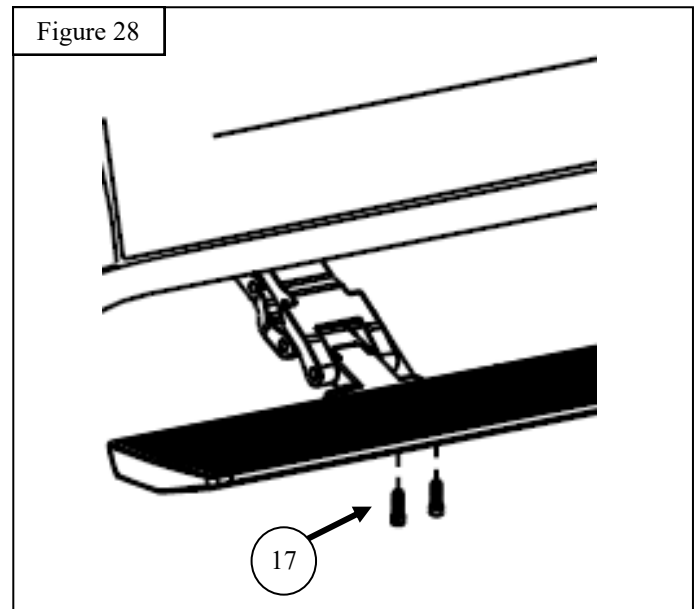
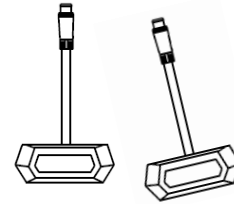
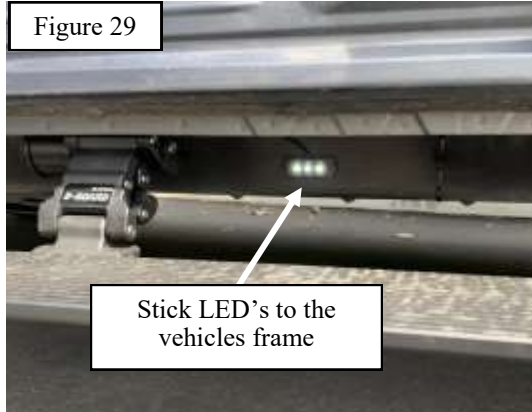
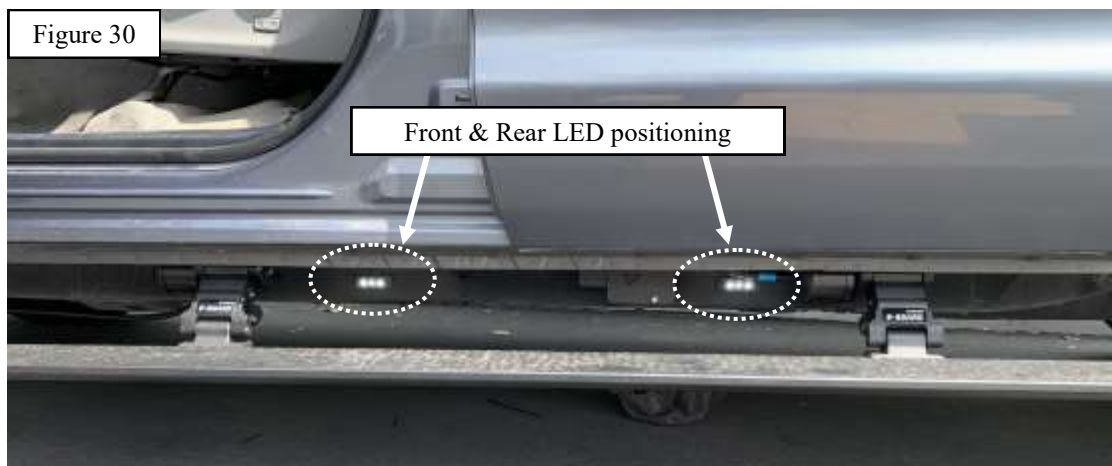
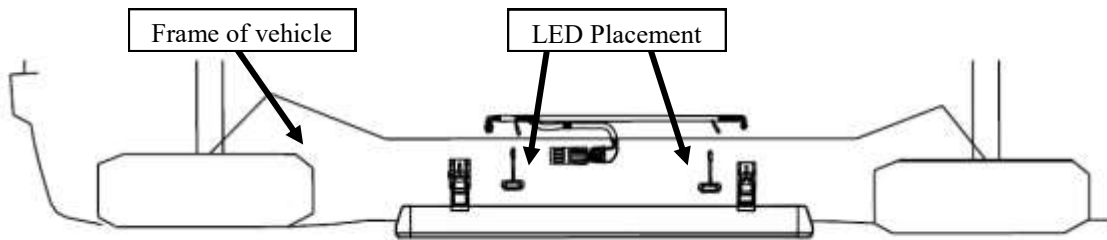

Figure 28

25. Locate the LED Lights (Item 11) and prepare the designated mounting surface on the vehicle frame rail by cleaning it with a damp rag with 50/50 mix of isopropyl alcohol and water, allow the surface to dry completely before peeling the backing off the double sided tape and sticking the LED lights to the designated mounting surface. (See **Figures 29 & 30** for reference).



Place two LED's on each side to illuminate step bar when door is opened.



26. Route the electrical harness to the designated locations of the control module and motor linkages. Route the corresponding male connector plug to where the corresponding female connector are per the labeling on the harness and motor linkage then connect them to the control module linkages. For example, the male connector labeled “Front Left,” will be routed to the front driver side of the vehicle, and the “Front Right” should be routed to the front passenger side of the vehicle. The male connectors for the control module will be routed to the center driver side. (See **Figures 31 through 33** for reference). For the LED’s align the arrows on the LED Light male connectors to the arrow on the female connector on the main wiring harness.

Figure 31

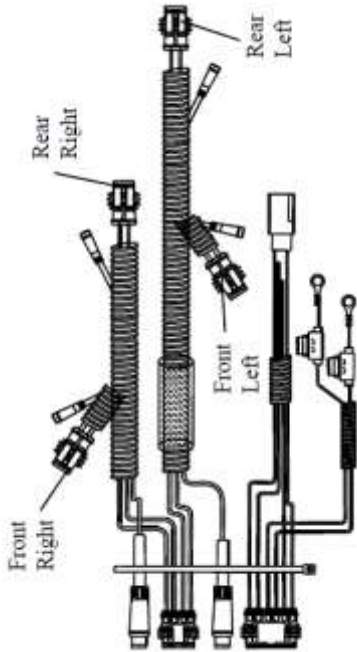

Figure 32

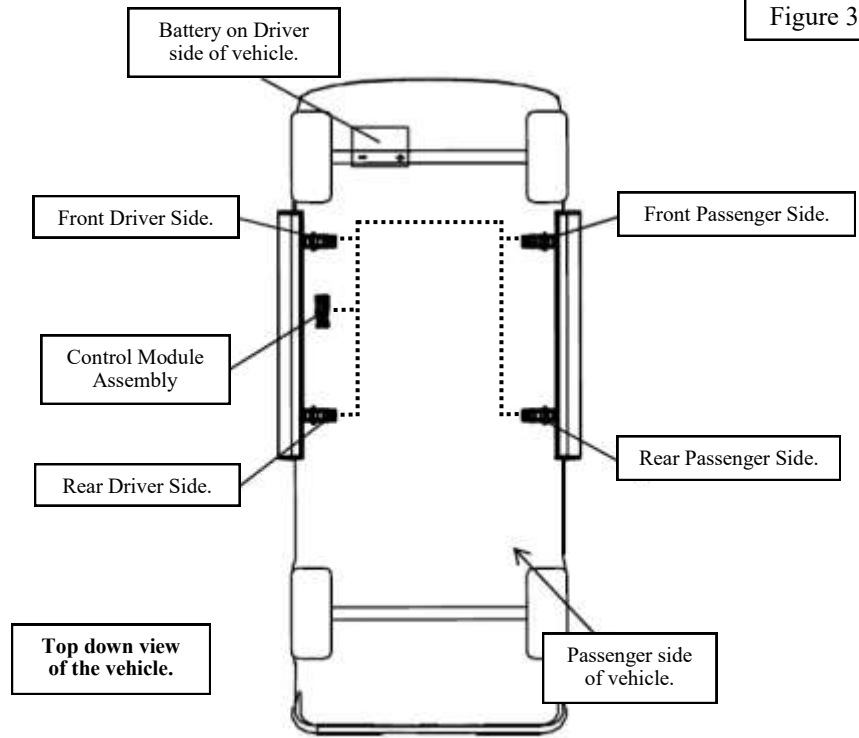

Figure 33

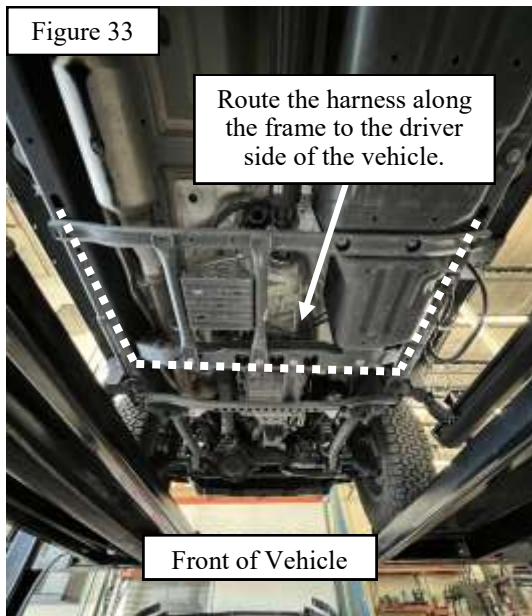
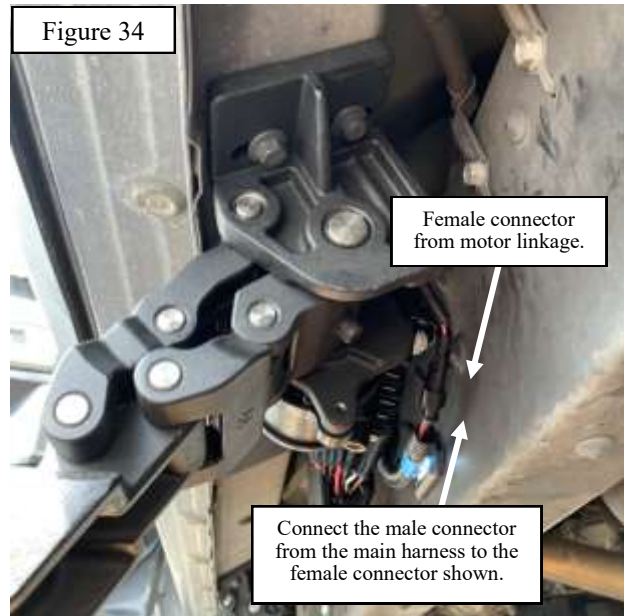
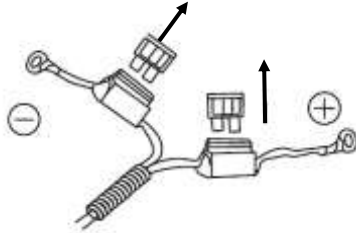

Figure 34



27. With all of the motor linkages, LED Lights, and control module plugs securely connected, return to the two control input wires in the engine compartment. Firstly remove the two fuses (Item 13) from both power wires. Then carefully connect the positive (**Red Wire**) to the positive battery terminal and the negative (**Black Wire**) to the negative battery terminal. Once the wires are connected to the battery, reinstall the previously removed fuses and neatly tuck away all of the wiring using the provided zip ties (Item 7).



Remove fuses from both power wires before connecting to the battery

Figure 35



28. With all of the wiring connectors securely plugged in, open the driver side door and ensure that the manual switch is in the off position. This signals the control module to retract and it will disable the operation of the running boards until it switched to the on position.
29. Open and close all of the vehicles doors one by one to ensure that the running boards operate appropriately. If the running boards operate properly, the installation is complete. If they do not, check all the wiring connections and make sure that the magnets on the door striker align with their corresponding control module.

Note: Any misalignment between the magnets on the door strikers and their corresponding Magnetic Control Module can prevent the running boards from opening and closing properly.

30. With the running boards operating properly, neatly tuck away all wiring using the provided zip ties (Item 7).



Westin Automotive Products, Inc.
320 W. Covina Blvd
San Dimas, Ca. 91773

Thank you for choosing Westin products
for additional installation assistance please call
Customer Service (800) 793-7846
www.westinautomotive.com

INSTALLATION COMPLETE



CARE INSTRUCTIONS

- REGULAR WAXING IS RECOMMENDED. DO NOT USE ANY TYPE OF POLISH OR WAX THAT MAY CONTAIN ABRASIVES.
- STAINLESS STEEL PRODUCTS CAN BE CLEANED WITH MILD SOAP AND WATER. STAINLESS STEEL POLISH SHOULD BE USED TO POLISH SMALL SCRATCHES.
- GLOSS BLACK FINISHES SHOULD BE CLEANED WITH MILD SOAP AND WATER.



Westin Automotive Products, Inc.
320 W. Covina Blvd
San Dimas, Ca. 91773

Thank you for choosing Westin products
for additional installation assistance please call
Customer Service (800) 793-7846
www.westinautomotive.com



WARNING



Failure to follow these instructions could lead to death, personal injury, and / or property damage.

Failure to follow these instructions could lead to death, personal injury, and / or property damage.

FASTENERS:

All Westin supplied fasteners must be utilized and installed in accordance with the installation instructions and apply torque to the specifications as defined. **DOUBLE CHECK ALL FASTENERS BEFORE INITIAL USE, AND PERIODICALLY IN THE FUTURE TO ENSURE PROPER FUNCTION AND SAFETY.**

DRILLING:

Most Westin products do not require drilling for installation. If drilling is defined as required, use caution when drilling a vehicle. **FAILURE TO REVIEW AN AREA TO BE DRILLED MAY RESULT IN PERSONAL INJURY AND/OR INJURY TO OTHERS AS WELL AS VEHICLE DAMAGE.**

EYE PROTECTION:

ALWAYS WEAR SAFETY GLASSES OR GOGGLES DURING THE INSTALLATION PROCESS TO AVOID PERSONAL INJURY.

MAXIMUM TOWING/CARRYING CAPACITY: (if applicable)

The Westin Receiver Hitches will have a visible tow rating label affixed directly on the product. User should never exceed the vehicle manufacturers maximum tow and weight rating regardless of the capacity of the hitch. **FAILURE TO FOLLOW THESE GUIDELINES WILL VOID THE WESTIN WARRANTY AND MAY RESULT IN PERSONAL INJURY AND/OR INJURY TO OTHERS AS WELL AS VEHICLE DAMAGE.**

FOR CALIFORNIA RESIDENTS ONLY-PROP 65 WARNING:

Some products may contain chemicals such as DEHP, which can cause cancer, birth defects or other reproductive harm. For more info go to www.p65warnings.ca.gov



Westin Automotive Products, Inc.
320 W. Covina Blvd
San Dimas, Ca. 91773

Thank you for choosing Westin products
for additional installation assistance please call
Customer Service (800) 793-7846
www.westinautomotive.com