

# INSTALLATION INSTRUCTIONS

## ALUMINUM BED TOPPER



**APPLICATION:**  
Toyota Tacoma 16-23 6.0' Bed

**PART NUMBER:** 16-14185

CONTENT			
ITEM	QUANTITY	DESCRIPTION	TOOLS NEEDED
1	1	ROOF PANEL	13mm SOCKET
2	1	FRONT PANEL	12mm SOCKET
3	1	LEFT SIDE PANEL	10mm SOCKET
4	1	RIGHT SIDE PANEL	RATCHET
5	1	REAR DOOR	TORQUE WRENCH
6	1	PARTS KIT #1	5MM ALLEN KEY
7	1	PARTS KIT #2	PHILLIPS SCREW-DRIVER
8	1	PARTS KIT #3	T-30 TORX DRIVE BIT

**ANTI-SEIZE LUBRICANT MUST BE USED ON ALL STAINLESS STEEL FASTENERS TO PREVENT THREAD DAMAGE AND GALLING**

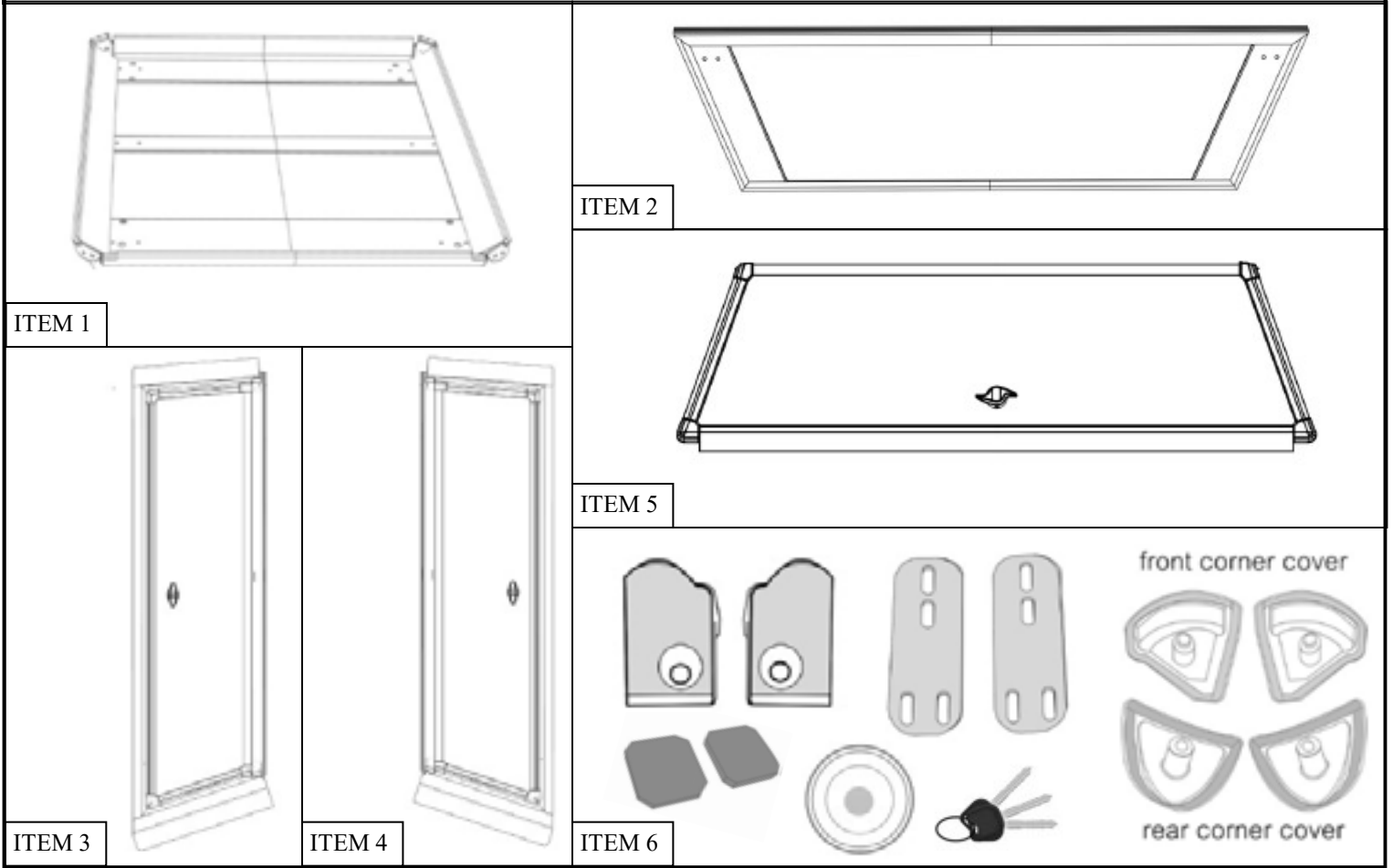

**WESTIN** Westin Automotive Products, Inc.  
320 W. Covina Blvd  
San Dimas, Ca. 91773

Thank you for choosing Westin products  
for additional installation assistance please call  
Customer Service (800) 793-7846  
www.westinautomotive.com

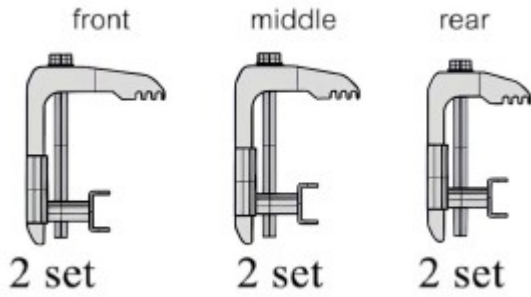

ITEM 7

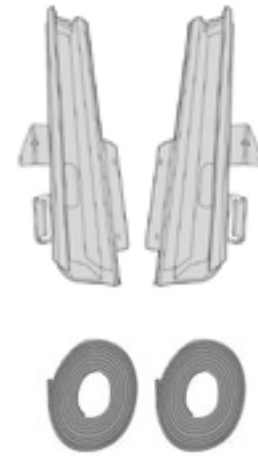

ITEM 8

**PROCEDURE**

1. Remove contents from box, verify if all parts listed are present and free from damage. Carefully read and understand all instructions before attempting installation. **Failure to identify damage before installation could lead to a rejection of any claim.**
2. With the roof panel secured on a flat surface, slide the rear door into the roof panel. (Fig. 1)
3. Next, use a Phillips screwdriver to screw the three (3) #6 x 3/8 pan head tapping screws from **Parts Kit #1 (Item 6)** to secure the rear door panel onto the roof panel. Cross section view A-A shows how the railing system works to attach these components together. (Fig. 2)

FIGURE 1

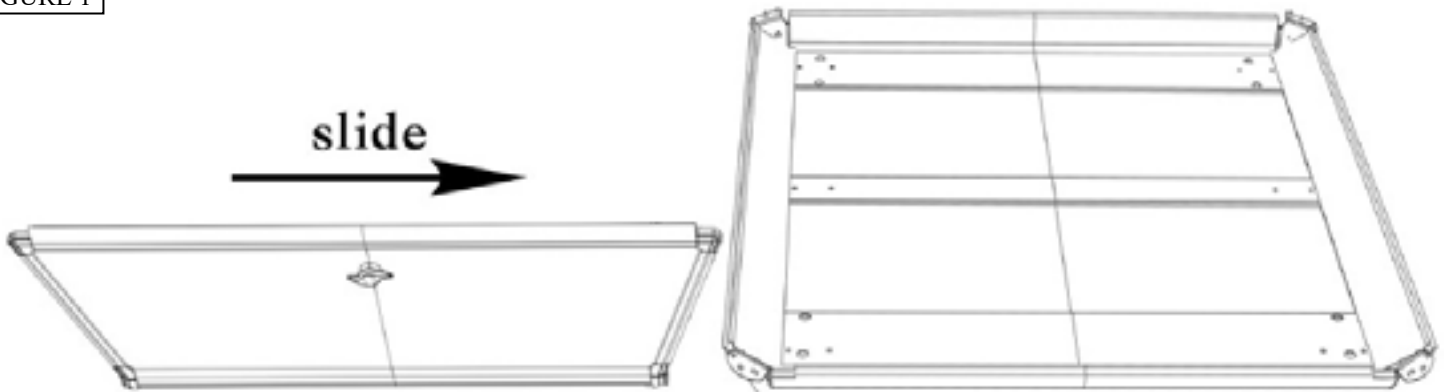
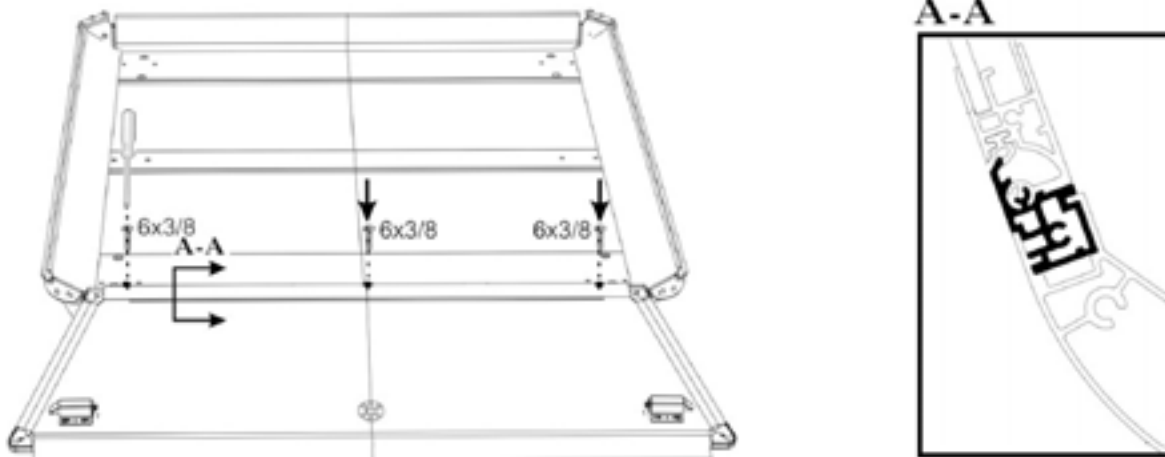
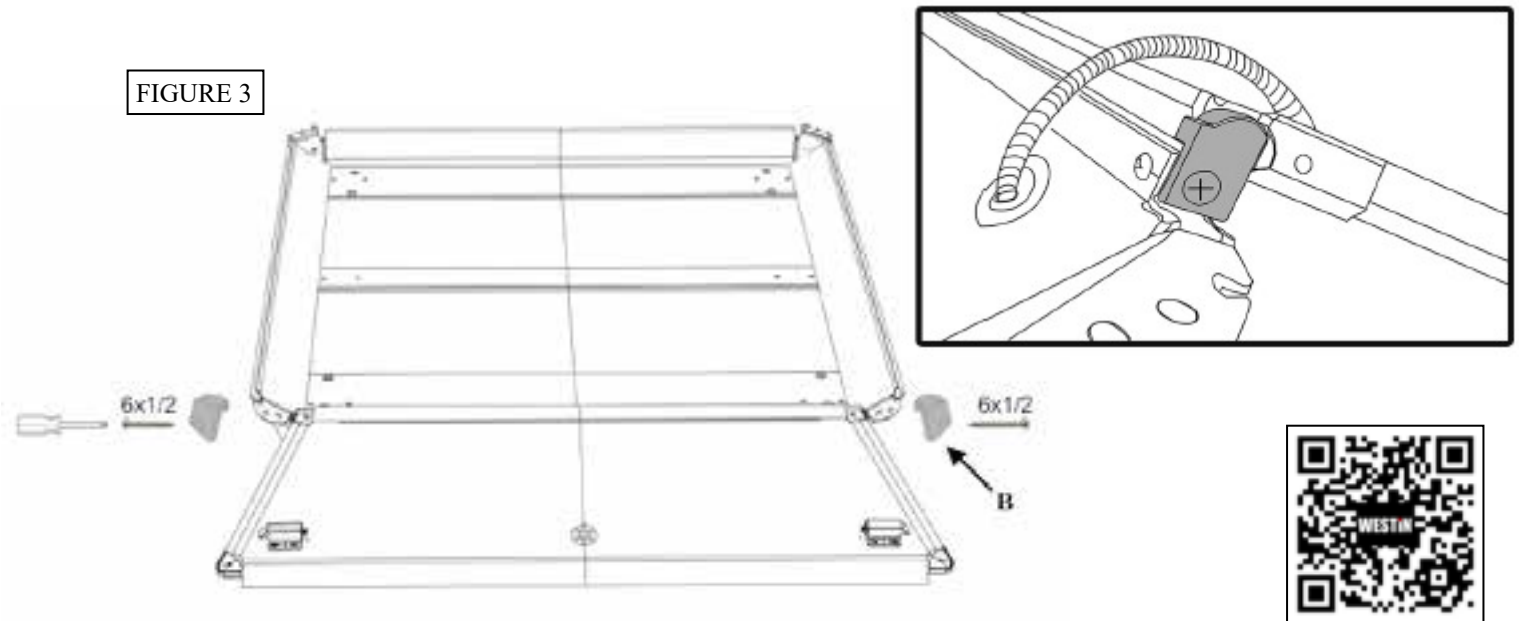

FIGURE 2



4. Screw in the rear door side covers using the two (2) #6 x 1/2 flat head tapping screws from **Parts Kit #1 (Item 6)**. The installation should look like the image below. (**Fig. 3**)



5. While lifting the rear door up, slide the left panel into the railing system. Section view A-A shows how the left panel slides into the roof panel. (**Fig. 4**)

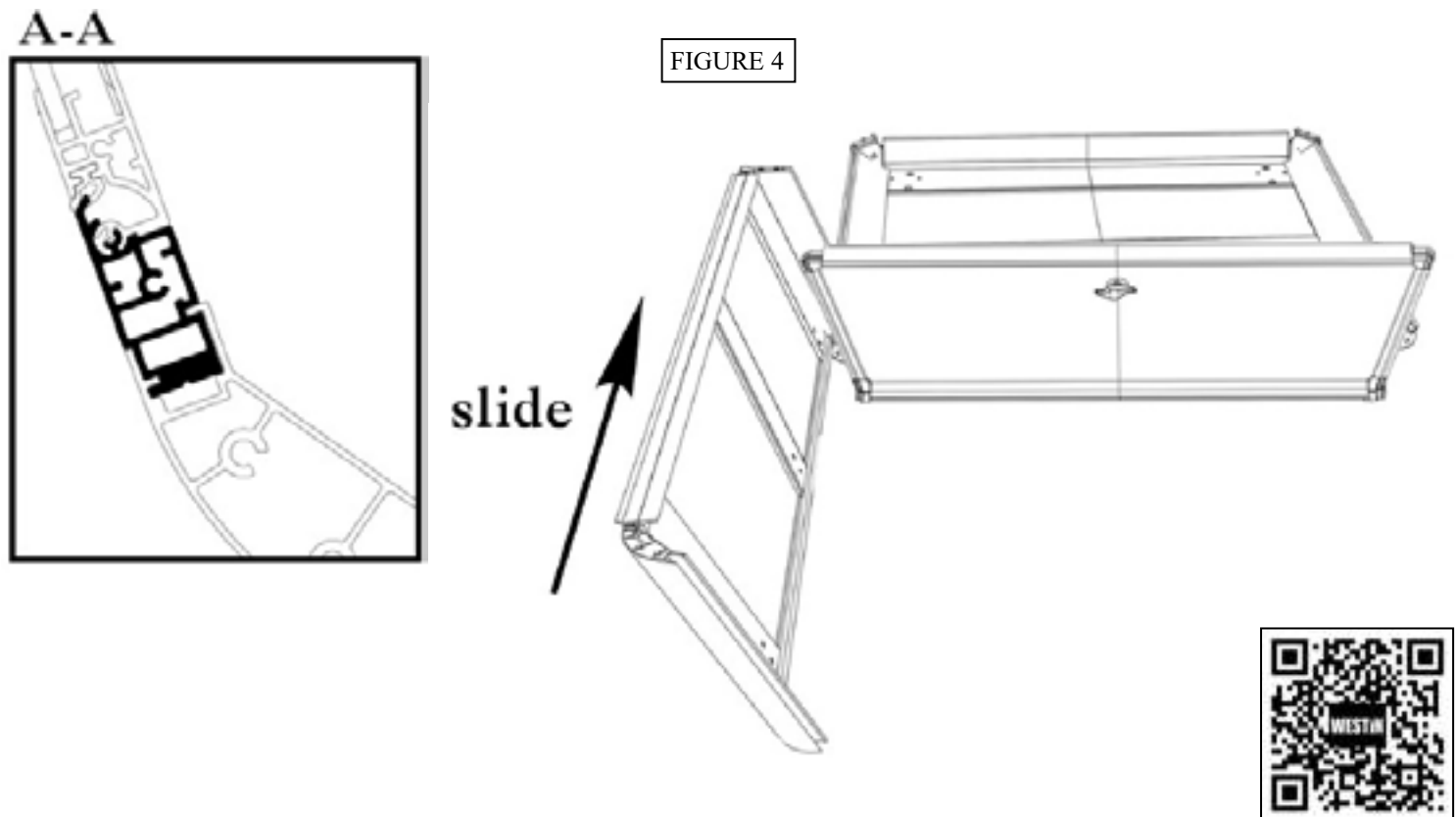

6. Repeat step 5 for the right panel. (Fig. 5)

FIGURE 5

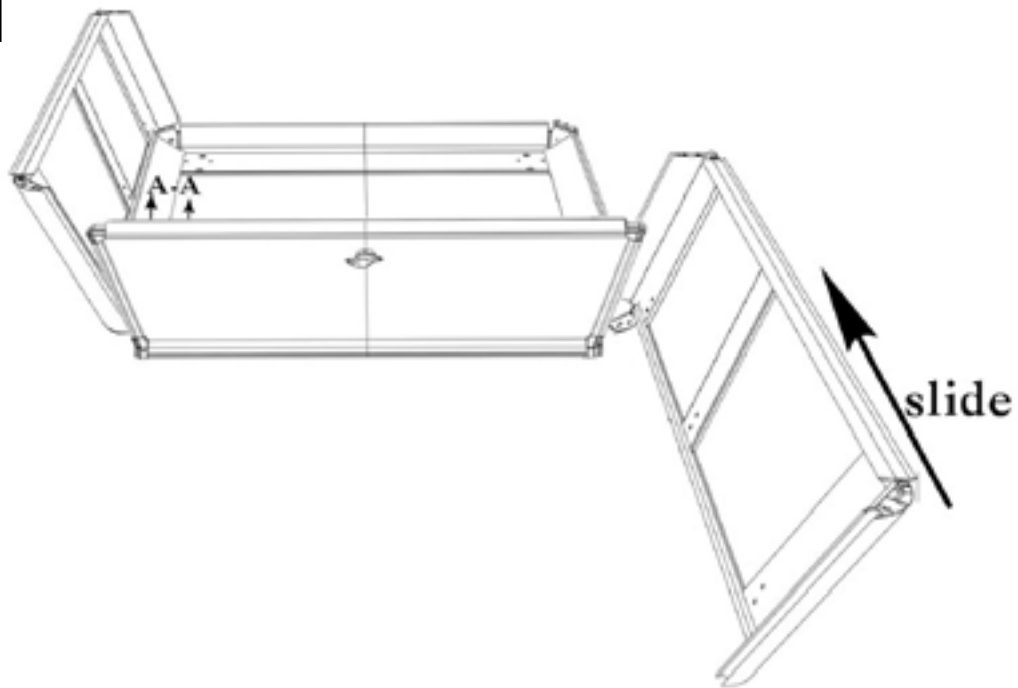

7. Next, push the front panel into the roof panel. (Fig. 6)

FIGURE 6

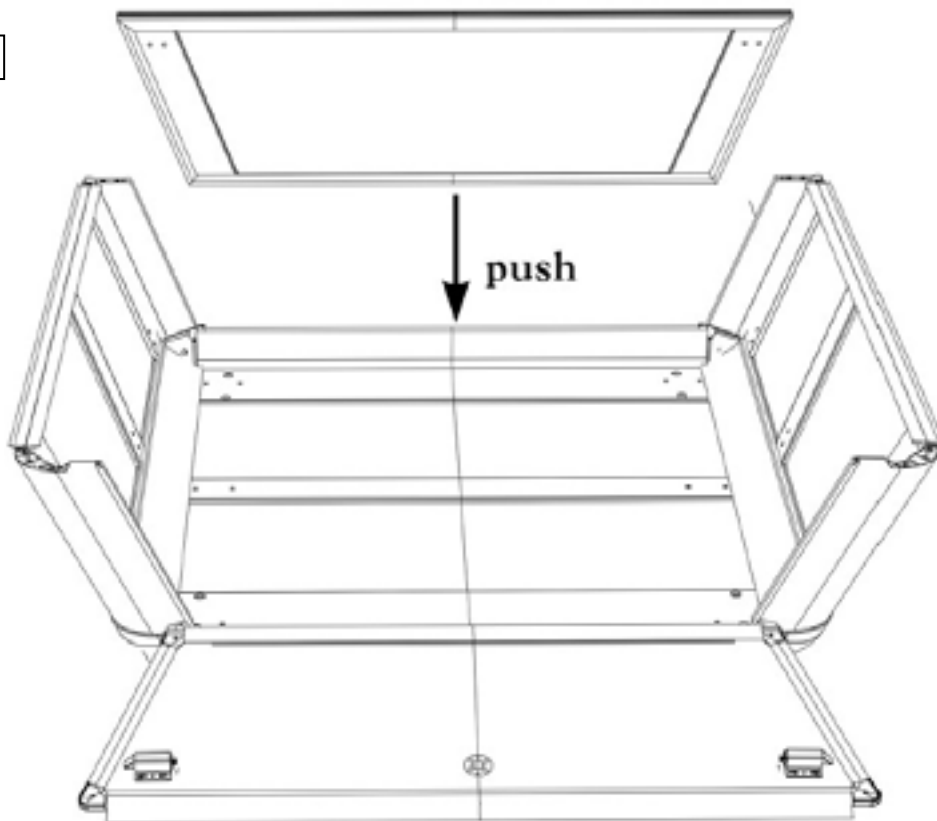

8. Push the left panel inwards towards the front panel. Using a front panel bracket, two (2) M8 x 12 socket pan head bolts, two (2) M8 split washers, two (2) M8 flat washers, two (2) M6 x 15 hex bolts, two (2) M6 split washers, and two (2) M6 flat washers provided in **Parts Kit #1 (Item 6)**, fasten the left panel to the front panel. Use a 5mm Allen Key and 10mm socket to initially tighten the bolts, then use a torque wrench to torque the M8 bolts to **10Nm (8ft-lbs)** and the M6 bolts to **5Nm (4 ft-lbs)**. Repeat this process to fasten the right panel to the front panel. (Fig. 7)

**CAUTION: MAKE SURE TO USE THE M8 X 12 SOCKET PAN HEAD BOLTS FOR THE MOUNTING HOLES ON THE FRONT GLASS, THEY REQUIRE A 5MM ALLEN KEY TO FASTEN. DO NOT USE THE M8 X 20 HEX BOLTS AS THIS MAY DAMAGE THE FRONT GLASS PANEL.**

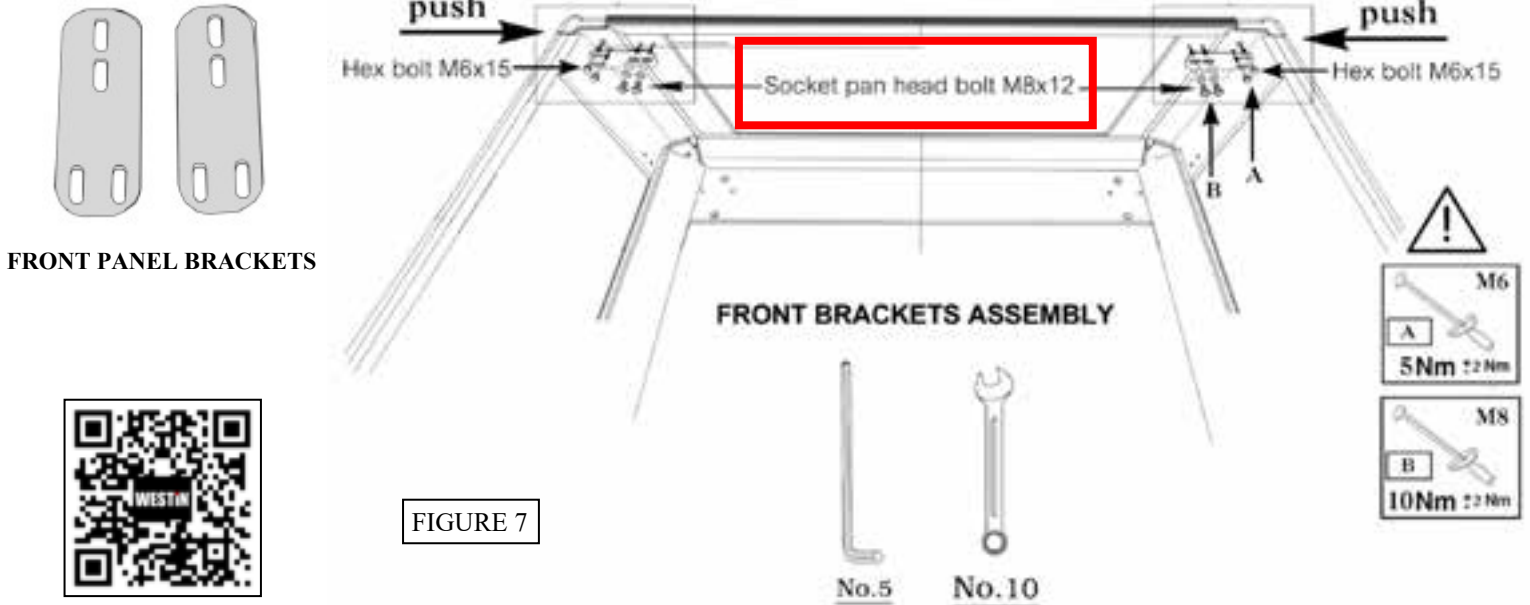

9. Connect the front wire found at the corner of the roof panel and front panel (Fig. 8). Then connect the rear wire (Fig. 9) and tuck the connectors into the roof panel. (Fig. 10)

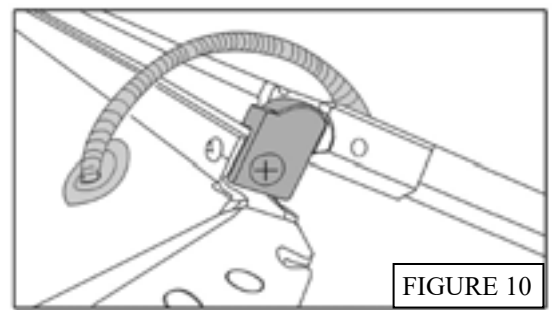
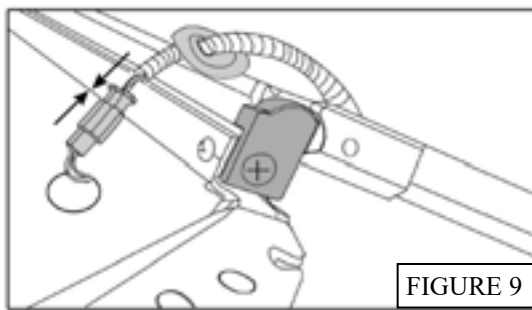
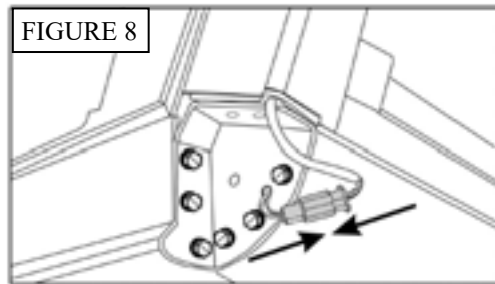

10. Next, use two (2) M8 x 20 Grade 8.8 hex bolts, two (2) M8 split washers, and two (2) M8 flat washers to fasten the front panel to the roof panel at one corner. Use a 13mm socket to initially tighten the bolts, then torque the bolts to **25Nm (19ft-lbs)**. Repeat this process for the other corner where the roof panel and front panel meet. (Fig. 11)

FIGURE 11

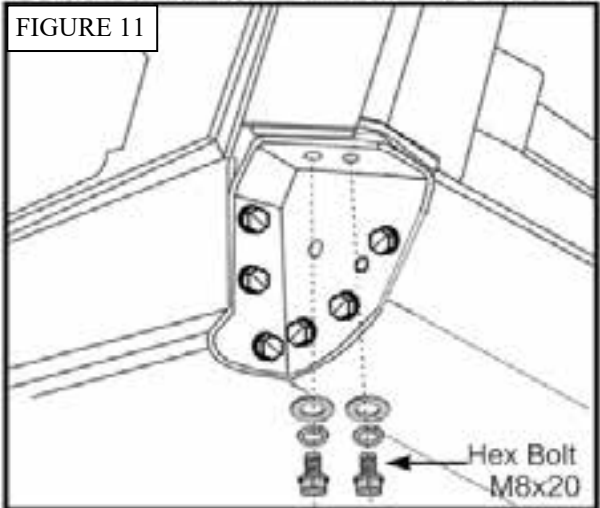

11. Repeat Step 10 for both corners where the roof panel and rear door meet. Use the same kind of hardware as in the previous step (Fig. 12). Connect the roof panel wire to the rear door connector as shown below. (Fig. 13)

FIGURE 12

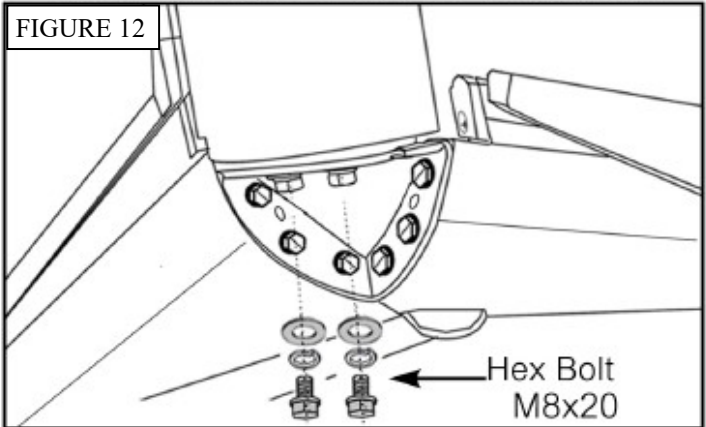
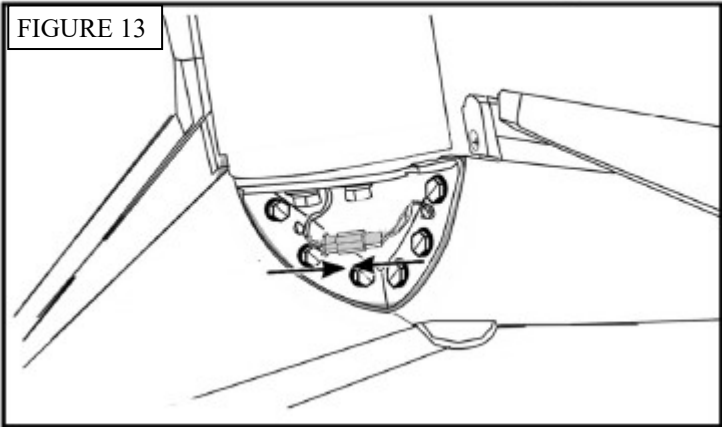
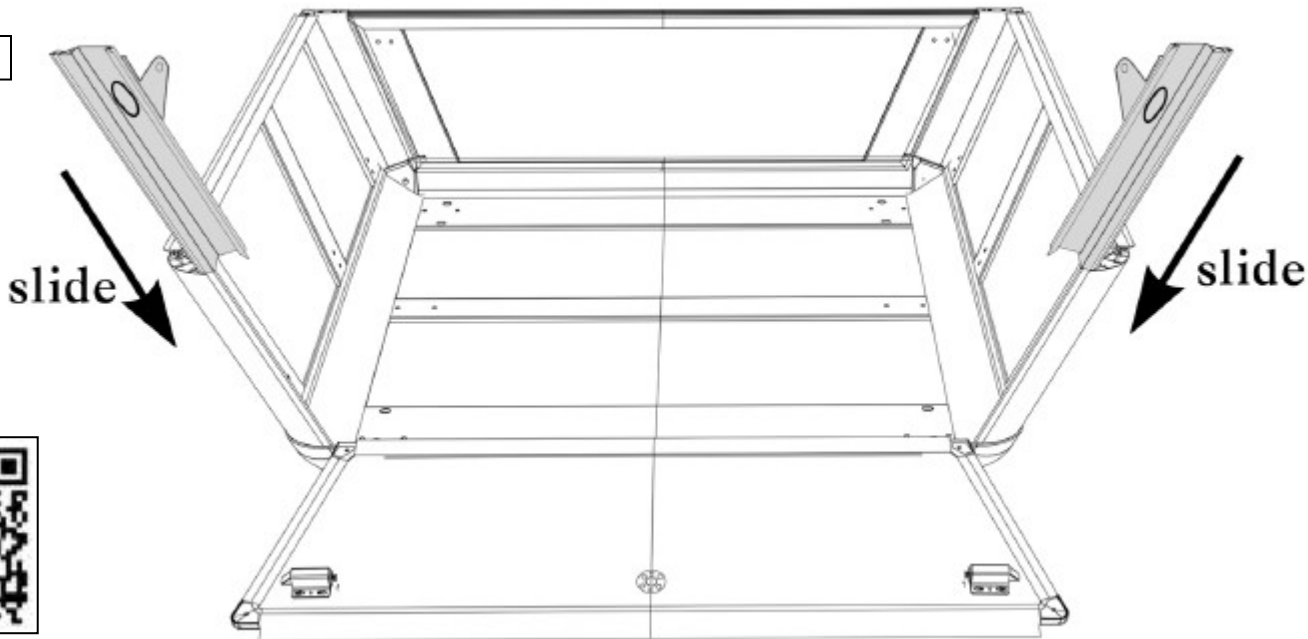

FIGURE 13



12. Slide the water channels downwards on the left and rear panels toward the rear door (Fig. 14). The water channels are found in **Parts Kit #3 (Item 8)**.

FIGURE 14



13. An inside corner of the rear door and side panel is shown below. Using the contents of **Parts Kit #3 (Item 8)** and a 12mm socket, fasten two (2) M8 x 20 hex bolts through the water channel bracket and into the side panel, torque to **10Nm (8ft-lbs)**. (Fig. 15) Next, use two (2) #6 x 3/8 pan head tapping screws and fasten the water channels to the side panels. (Fig. 16) Repeat this step for the other side of the topper.

FIGURE 15

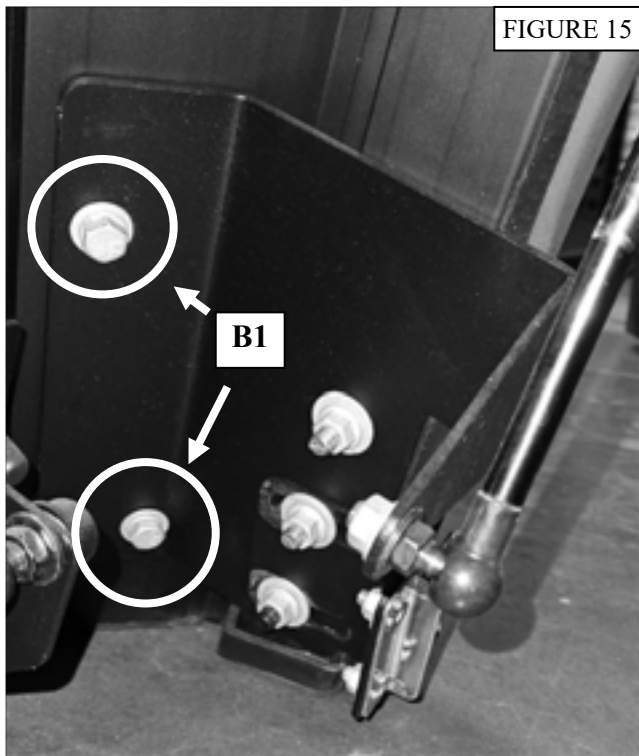

FIGURE 16



A1	
5 Nm ±2 Nm	
B1	
10Nm ±2 Nm	



14. Torque the nuts on the door latch to **5Nm (4ft-lbs)** using a 10mm socket. There are slots on the door latch bracket that allow for the latch to be adjusted so the rear door can close correctly. (**Fig 17**) Once the rear door is shut and the door latch is adjusted properly, torque the bolts in **Fig. 18** to **10Nm (8ft-lbs)**.

**SLOTS FOR ADJUSTABILITY**

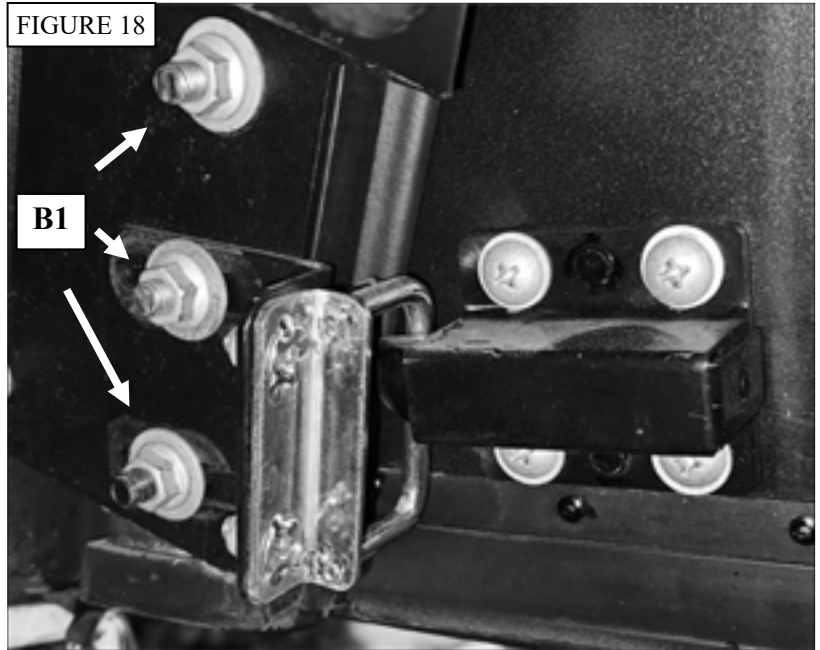
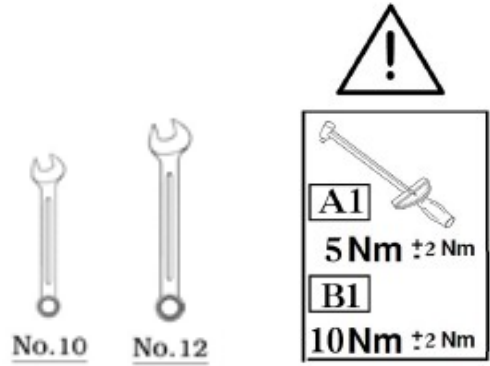
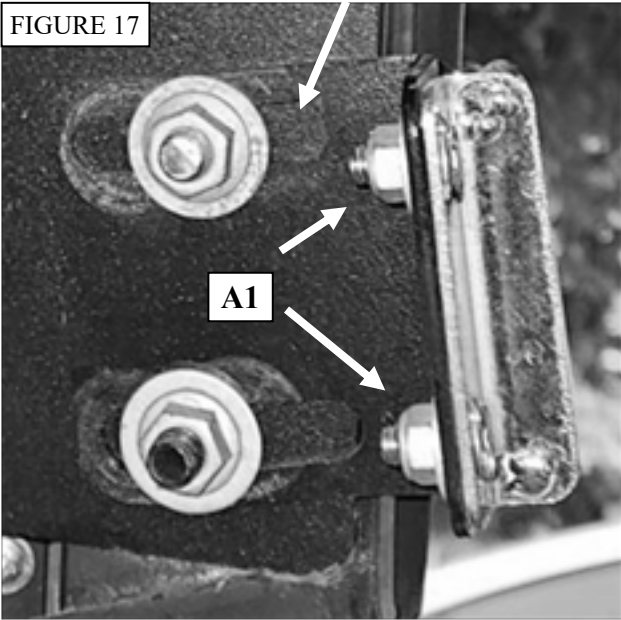



15. Next, clean the surface of the perimeter of the corner where the roof panel and left panel meet. Locate the silicone corner covers in **Parts Kit #1 (Item 6)** and remove the tape over the adhesive on the covers. While tucking the wires inwards into the roof panel, firmly press the cover over the corner (**Fig. 19**). Fasten the corner cover to the topper assembly using one (1) M6 x 10 pan head bolt and one (1) M6 flat washer also found in the same parts kit. The hardware fastens from the inside of the topper assembly. Repeat this step for installing the corner cover on the other side where the right panel meets the roof panel. (**Fig. 20**)

FIGURE 19

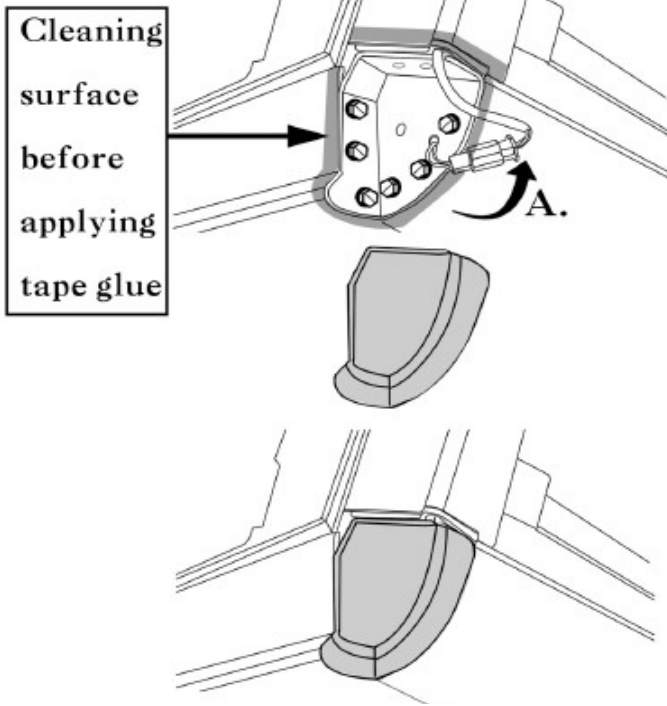
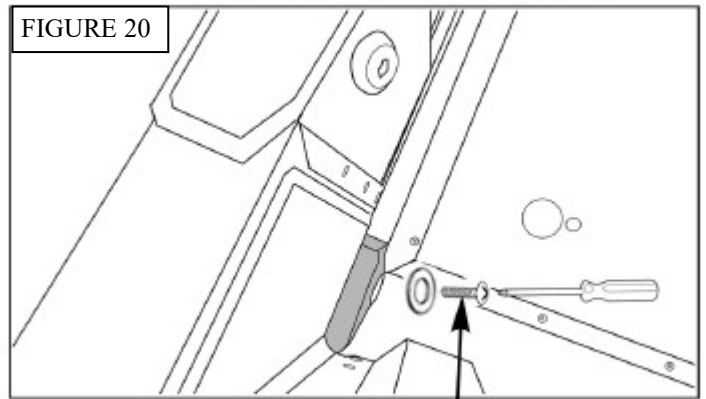

FIGURE 20



Pan Head Bolt M6x10



16. Repeat the process in Step 14 to install the corner covers on the rear corners of the topper assembly. (**Fig. 21**)

FIGURE 21

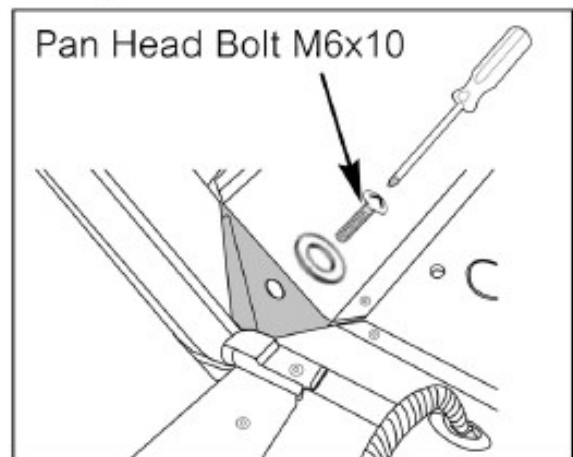
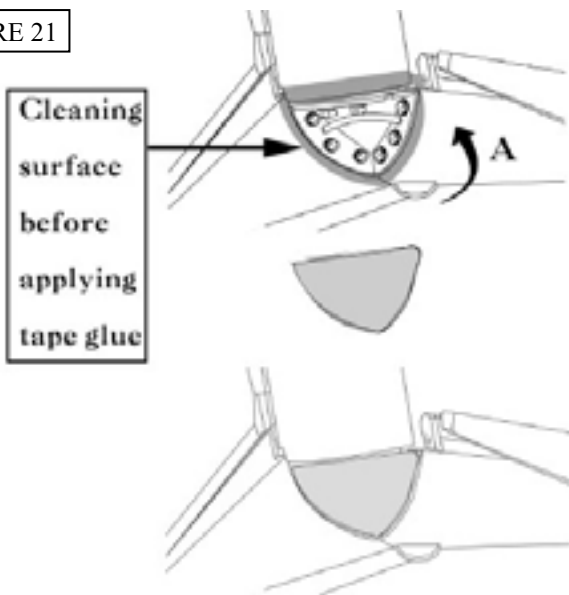

Pan Head Bolt M6x10

17. Use a T-30 Torx bit to remove the 5 screws on the front bed rail below the rear cab window. Remove the adhesive strip on the back of the foam filler caps, found in **Parts Kit #1** (Item 6), and attach them to the ends of the cab header. (**Fig. 22**)  
Reinstall the front bed rail.

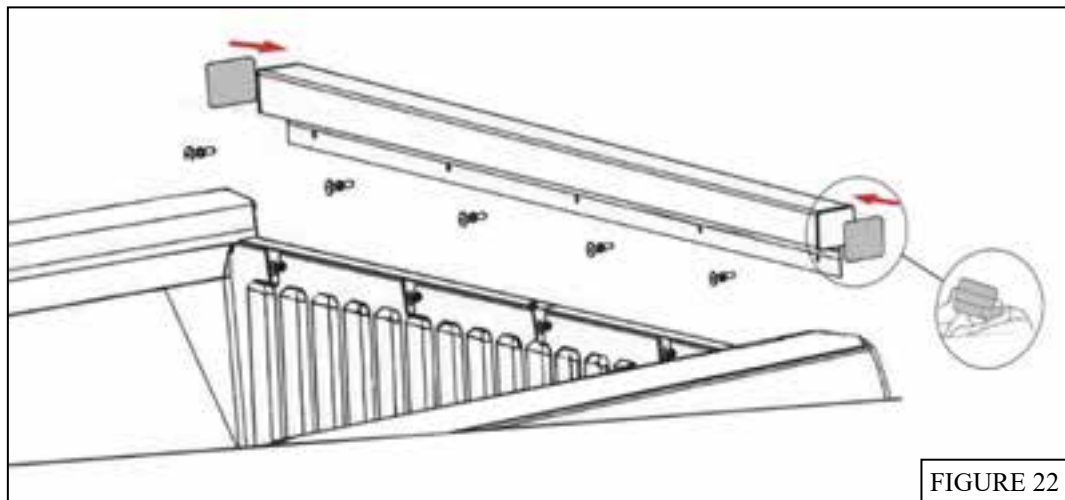
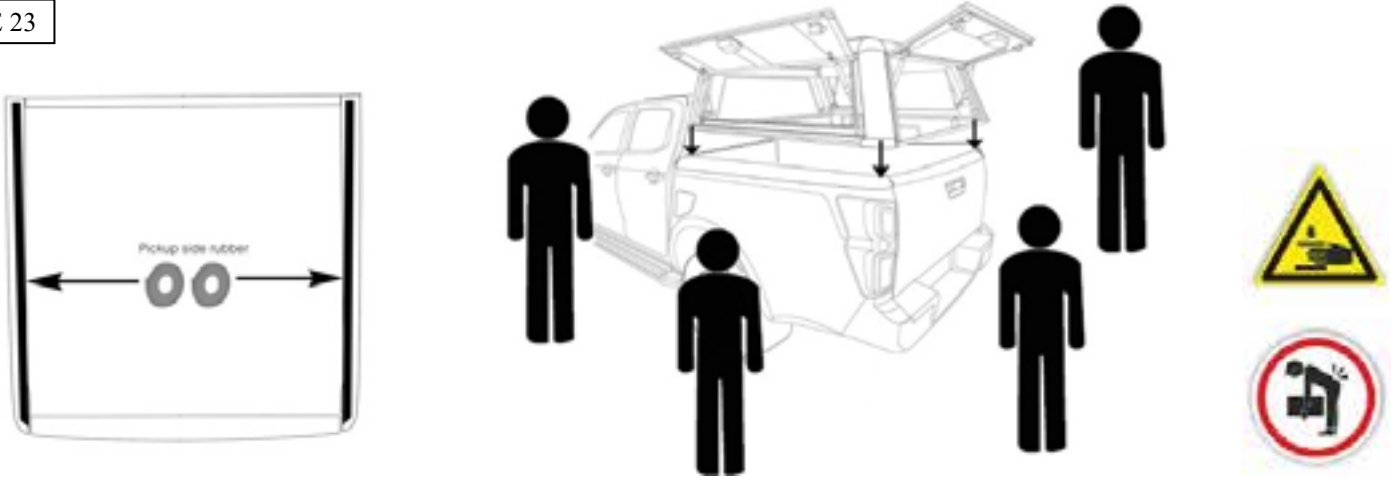

FIGURE 22

17. Apply the bed rail rubber strips from **Parts Kit #3 (Item 8)**, to the truck bed. Open the left, right, and rear panels before placing the topper onto the truck bed. A minimum of four people are recommended for this installation. Make sure to avoid dragging the topper across the truck bed rails. Handle with caution to avoid injury to hands and damage to the topper assembly and vehicle. (**Fig. 23**)

FIGURE 23



18. Locate the contents found in **Parts Kit #2 (Item 7)** and correctly place each labeled clamp on both bed rails (**Fig. 24**). Use a 13mm socket to initially tighten the clamps, then torque to **6Nm (4.4ft-lbs)**. The tightened clamp should resemble (**Fig. 25**).

FIGURE 24

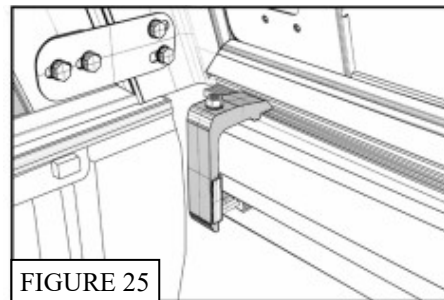
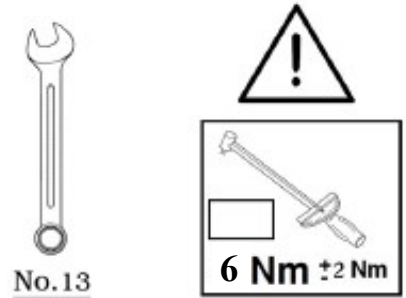
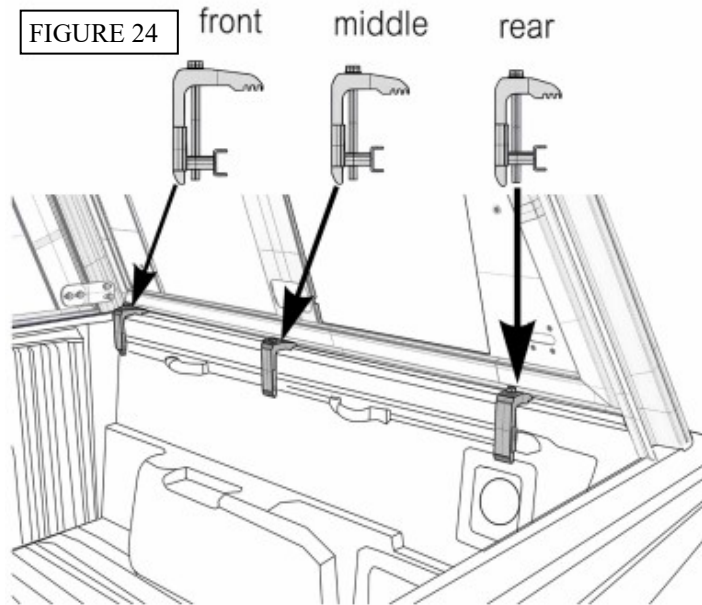

19. Once the bed topper is placed on the vehicle, adjustment may be required to allow for the topper to sit well onto the bed rails. If adjustment is needed, loosen the front bracket and push the sides doors inward towards each other and make sure the gap (circled in Fig. 26) is closed. Tighten the front bracket as mentioned in Step 8.



21. Use the nuts already installed on the end of the gas studs to secure the studs to the rear door using a 12mm socket. (**Fig. 27**)

22. To connect the brake light on the topper to the vehicle's tail light, remove one of the vehicle's tail lights. Use a 10mm socket to remove the two bolts that attach the tail light to the vehicle. Remove the middle connector from the back of the tail light. (**Fig. 28**) Using the topper wiring harness that is located towards the rear of the topper, splice the topper red wire to the tail light blue wire, then splice the topper yellow wire to the green wire. Plug the connector back into the tail light and check that the topper brake light turns on with the vehicle's tail lights, then reinstall the tail light.

**Note:** (**Fig. 29**) shows how the topper brake light can be tested with the brake pedal pressed, before the wires are spliced together.

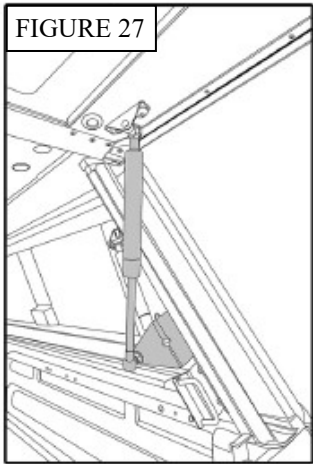

23. The topper's rear door has a locking function that connects to the vehicle's tailgate locking actuator. The wiring harness located at the front of the topper will be used for this function. First, use a T-30 Torx Drive Bit to remove the 16 bolts on the inside of the tailgate, then remove the two tailgate covers. (**Fig. 30**)



24. **Fig. 31** shows which wire will be used to connect with the topper's front wiring harness. Next, route the topper's wiring harness under the vehicle's bed and towards the back of vehicle, making sure the harness is secured and away from the any spinning components. (**Fig. 32**) Then route the harness through the opening in the bed (**Fig. 33**) and into the tailgate. Finally, splice the topper red wire to the actuator's green wire, and splice the topper black wire to the blue wire. (**Fig. 34**) Plug the tailgate actuator connectors back together and test that the topper's locking function works properly when the vehicle is locked and unlocked. Reinstall the tailgate covers.

**Note:** Check the connector's at the corners (**Fig. 8** and **Fig. 13**) of the topper are properly connected and the wires are pushed correctly into the connectors.

An auxiliary light and key set are include in the topper packaging.

The installation of your Westin Automotive Bed Topper is complete!

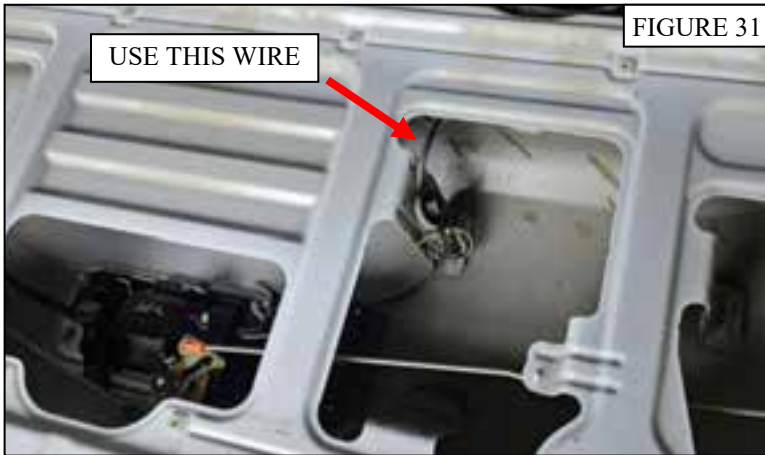



## WARNING



Failure to follow these instructions could lead to death, personal injury, and / or property damage.

Failure to follow these instructions could lead to death, personal injury, and / or property damage.

### FASTENERS:

All Westin supplied fasteners must be utilized and installed in accordance with the installation instructions and apply torque to the specifications as defined. **DOUBLE CHECK ALL FASTENERS BEFORE INITIAL USE, AND PERIODICALLY IN THE FUTURE TO ENSURE PROPER FUNCTION AND SAFETY.**

### DRILLING:

Most Westin products do not require drilling for installation. If drilling is defined as required, use caution when drilling a vehicle. **FAILURE TO REVIEW AN AREA TO BE DRILLED MAY RESULT IN PERSONAL INJURY AND/OR INJURY TO OTHERS AS WELL AS VEHICLE DAMAGE.**

### EYE PROTECTION:

**ALWAYS WEAR SAFETY GLASSES OR GOGGLES DURING THE INSTALLATION PROCESS TO AVOID PERSONAL INJURY.**

### MAXIMUM TOWING/CARRYING CAPACITY: (if applicable)

The Westin Receiver Hitches will have a visible tow rating label affixed directly on the product. User should never exceed the vehicle manufacturers maximum tow and weight rating regardless of the capacity of the hitch. **FAILURE TO FOLLOW THESE GUIDELINES WILL VOID THE WESTIN WARRANTY AND MAY RESULT IN PERSONAL INJURY AND/OR INJURY TO OTHERS AS WELL AS VEHICLE DAMAGE.**

### FOR CALIFORNIA RESIDENTS ONLY-PROP 65 WARNING:

Some products may contain chemicals such as DEHP, which can cause cancer, birth defects or other reproductive harm. For more info go to [www.p65warnings.ca.gov](http://www.p65warnings.ca.gov)



Westin Automotive Products, Inc.  
320 W. Covina Blvd  
San Dimas, Ca. 91773